



## ABOUT THIS MANUAL AND MT XPRESS

Thank you for purchasing an **MT Xpress** product.

All of our equipment is assembled and packed with great care. If you should find any incorrect item, please contact your **Xpress** Dealer immediately.

**MT Xpress** products are Weights & Measures approved precision weighing instruments. However, you may want to obtain official certification through your supplier or local Weights & Measures office.

This **MT Xpress** product was developed, produced, and tested in a METTLER TOLEDO facility that has been audited and registered according to international ISO 9001 quality standards and ISO 14000 environment control program. Properly used and maintained, this product will provide years of accurate weighing. Handle it as you would any piece of fine electronic equipment.

Please READ this manual BEFORE operating or servicing this equipment. Follow the instructions carefully and save this manual for future reference.

We at **MT Xpress** want to make sure you received the product you expected. It is important to us that you are satisfied with your purchase. If there is anything we can help you with, or if you are not satisfied with either your product or the services received from the **Xpress** representative, let us know.

### How can you reach us?

## XPRESS CUSTOMER CARE CENTER, USA















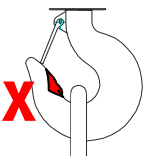

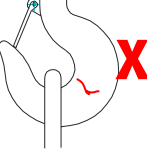
24/7 Information and Support: [www.mt.com/xpress](http://www.mt.com/xpress)  
[xpress@mt.com](mailto:xpress@mt.com)

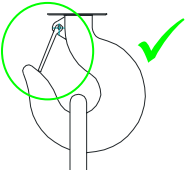

8 AM to 8 PM EST Toll Free: 1-866-MTXPRESS

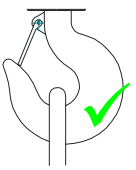
**Xpress**  
Mettler-Toledo, Inc.  
60 Collegeview  
Westerville, OH 43081

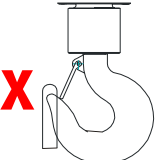
**FCC APPROVAL**

**This device complies with part 15 of the FCC Rules. Operation is subject to the following two conditions: (1) this device may not cause harmful interference, and (2) this device must accept any interference received, including interference that may cause undesired operation.**

	<p style="text-align: center;"> <b>WARNING</b></p> <p>ONLY PERMIT QUALIFIED PERSONNEL TO SERVICE THIS EQUIPMENT. EXERCISE CARE WHEN MAKING CHECKS, TESTS, AND ADJUSTMENTS THAT MUST BE MADE WITH POWER ON. FAILURE TO OBSERVE THIS PRECAUTION COULD RESULT IN BODILY INJURY.</p>
	<p style="text-align: center;"> <b>WARNING</b></p> <p>NEVER LIFT MORE THAN THE CRANE SCALE'S ASSIGNED WORKING LOAD LIMITED (WLL) RATING.</p>
	<p style="text-align: center;"> <b>WARNING</b></p> <p>DON'T USE ANY LOAD BEARING COMPONENT THAT IS WORN BEYOND 5% OF THE ORIGINAL DIMENSION.</p>
	<p style="text-align: center;"> <b>WARNING</b></p> <p>DO NOT USE THIS PRODUCT IF ANY OF THE COMPONENTS ARE CRACKED</p>
	<p style="text-align: center;"> <b>WARNING</b></p> <p>NEVER POSITION THE LOAD OVER A HUMAN OR ANY BODY PART</p>
	<p style="text-align: center;"> <b>WARNING</b></p> <p><b>BOTH THE CRANE AND SCALE SAFETY LATCHES MUST BE IN GOOD CONDITION AND IN PLACE.</b></p>
	<p style="text-align: center;"> <b>WARNING</b></p> <p>THE CRANE SCALE HOOK MUST ALWAYS SUPPORT THE LOAD CORRECTLY.</p>
	<p style="text-align: center;"> <b>WARNING</b></p> <p>THE SAFETY LATCH MUST NEVER SUPPORT THE LOAD.</p>

	<p data-bbox="799 210 1084 277"> <b>WARNING</b></p> <p data-bbox="574 298 1305 365">LOADS MAY DISENGAGE FROM CRANE SCALE HOOK AND SHACKLE IF PROPER PROCEDURES ARE NOT FOLLOWED.</p>
	<p data-bbox="799 407 1084 474"> <b>WARNING</b></p> <p data-bbox="799 512 1149 546">DO NOT LET LOADS SWING.</p>
	<p data-bbox="799 592 1084 659"> <b>WARNING</b></p> <p data-bbox="574 697 1360 730">DO NOT LEAVE THE CONTROLS WHILE A LOAD IS SUSPENDED</p>
	<p data-bbox="799 781 1084 848"> <b>WARNING</b></p> <p data-bbox="574 869 1305 936">LOADS MAY DISENGAGE FROM CRANE SCALE HOOK AND SHACKLE IF PROPER PROCEDURES ARE NOT FOLLOWED.</p>
	<p data-bbox="799 978 1084 1045"> <b>WARNING</b></p> <p data-bbox="717 1083 1224 1117">OPERATE THE CRANE AT A SAFE SPEED.</p>

## CONTENTS

<b>PREPARING THE SCALE FOR USE .....</b>	<b>9</b>
UNPACKING .....	9
POWER SUPPLY .....	12
HANGING THE SCALE .....	12
SIZING THE SCALE (IMPORTANT NOTE) .....	12
VERIFYING THE SCALE .....	13
CALIBRATING THE SCALE .....	13
TURNING THE SCALE ON/OFF .....	13
ZERO FUNCTION .....	14
RECOMMENDATIONS FOR USE .....	14
BATTERY NOTICE .....	14
<b>YOUR XPRESS SCALE AT A GLANCE .....</b>	<b>15</b>
SAFETY NOTICE .....	15
HANDLING HOIST MOTION .....	16
DISPLAY .....	16
CURSORS .....	16
KEYBOARD .....	17
REMOTE CONTROLLER .....	18
<b>OPERATING YOUR SCALE .....</b>	<b>20</b>
PUSH-BUTTON TARE .....	19
NUMERIC TARE .....	19
CLEAR (REMOVAL OF TARE WEIGHT) .....	19
WEIGHING (NORMAL GROSS WEIGHT) .....	19
ACCUMULATING .....	19
MANUAL TOTAL .....	20
AUTO TOTAL .....	20
RECALL .....	21
CLEAR THE ACCUMULATOR .....	21
PEAK WEIGHING OPERATION .....	21
LOAD HOLD .....	22
SELF TEST .....	22
SLEEP MODE .....	22
BRIGHTNESS ADJUSTMENT .....	22
PRINTING .....	22
TURNING THE SCALE OFF .....	22
<b>SCALE SOFTWARE SETUP .....</b>	<b>26</b>
SETUP PARAMETERS OVERVIEW .....	23
TO ENTER MASTER MODE .....	24
SPECIAL FUNCTION GROUP .....	24
<b>CLEANING AND MAINTAINING YOUR SCALE .....</b>	<b>33</b>
REGULAR MAINTENANCE AND INSPECTION .....	30
CLEANING .....	31
POWER SUPPLY AND CHARGING .....	31
TROUBLESHOOTING .....	32

---

<b>SERVICING YOUR SCALE</b> .....	<b>36</b>
TO ENTER SERVICE MODE .....	33
CALIBRATION GROUP .....	33
DISPLAYS .....	37
APPLICATION GROUP .....	38
BATTERY REPLACEMENT .....	40
<b>APPENDIX</b> .....	<b>44</b>
DEFAULT SETUP PARAMETERS .....	41
ERROR MESSAGES .....	42
SPECIFICATIONS .....	43
GEO VALUE TABLE .....	44
PHYSICAL DIMENSIONS .....	45

Please follow the proper loading procedure:

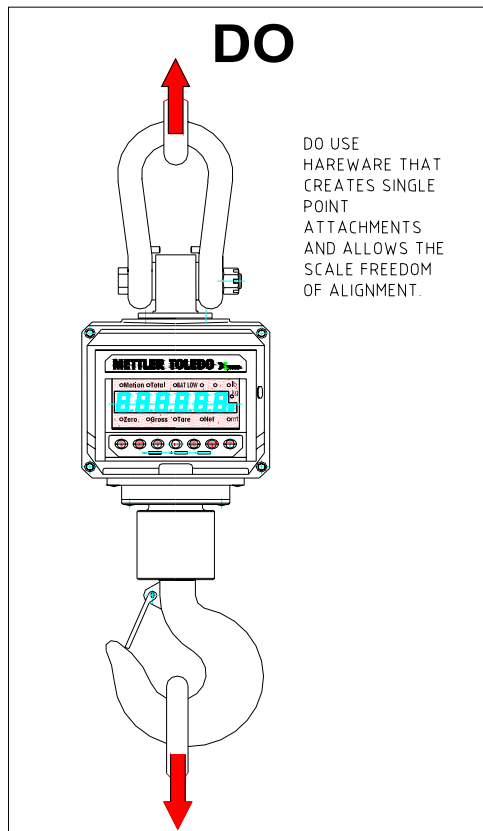
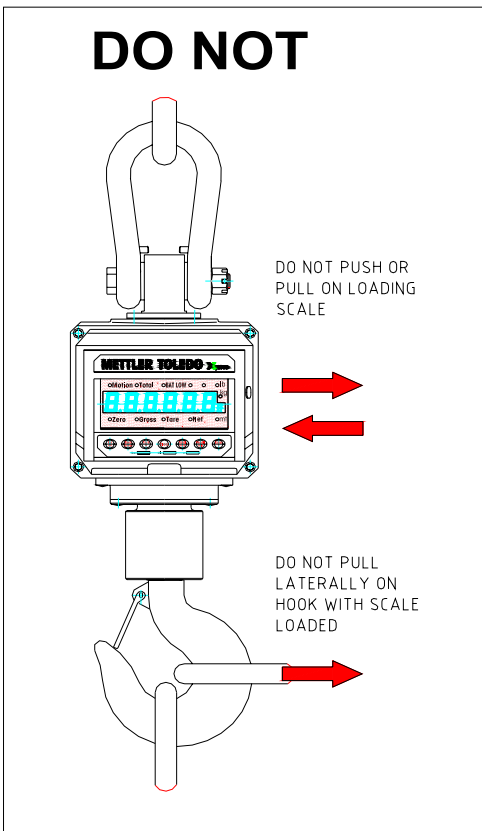
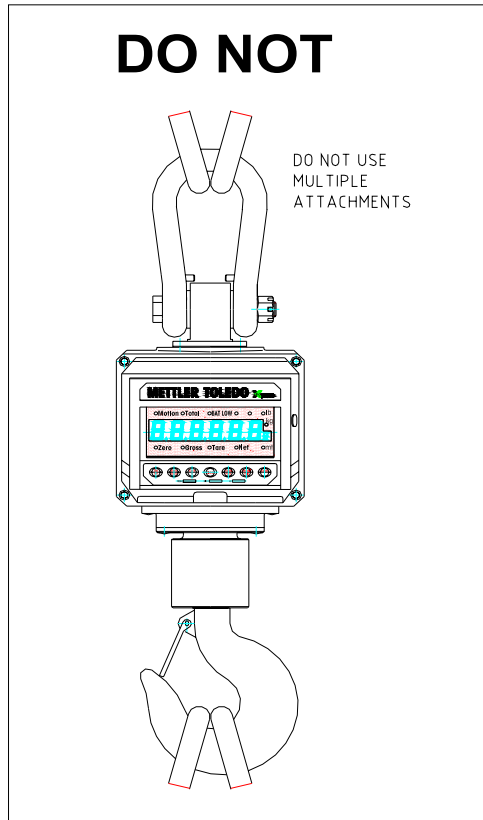
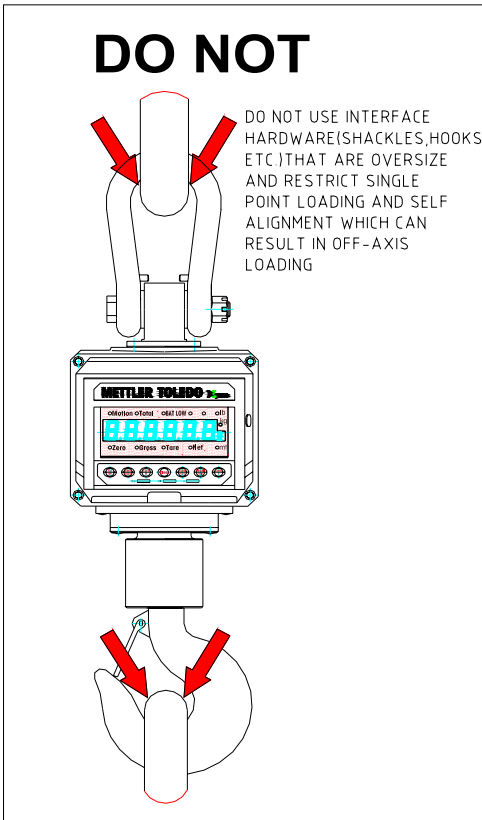



## PREPARING THE SCALE FOR USE

### UNPACKING

This device is compact and relatively heavy. Take every precaution to insure that you do not strain your back

- Have two people remove the scale from the shipping container.
- Use a power-lifting device such as a crane or forklift.
- Secure the scale to insure it doesn't drop when lifting.
- Do not stand under the scale.

When unpacking the scale from the shipping container, insure that all parts are accounted for. Check the scale for any visible damage and immediately report to your shipper. Any questions, please contact your local **Xpress** representative. Package contents for all **Xpress** Standard Crane Scales include:

#### Product

- Crane Scale
- Upper Shackle
- Lower Hook
- Remote Controller
- Transformer (charger)
- Battery Pack

#### Documents

- Quick Start Guide
- Installation Instructions

#### CD-ROM

- Operation & Service Manual

Look at the drawing below and install the upper shackle. First remove the horizontal pin, two washers, secure nut and cotter pin from the upper shackle (They are normally packed together.). Second hold the shackle vertically over the pin extending from the crane scale body shackle. Next, insert the horizontal pin and both washers over the shackle by inserting. (Each washer should be placed between the shackle and the vertical pin extending from the scale body.)

Proper installation of the upper shackle (See the next diagram for proper installation.):

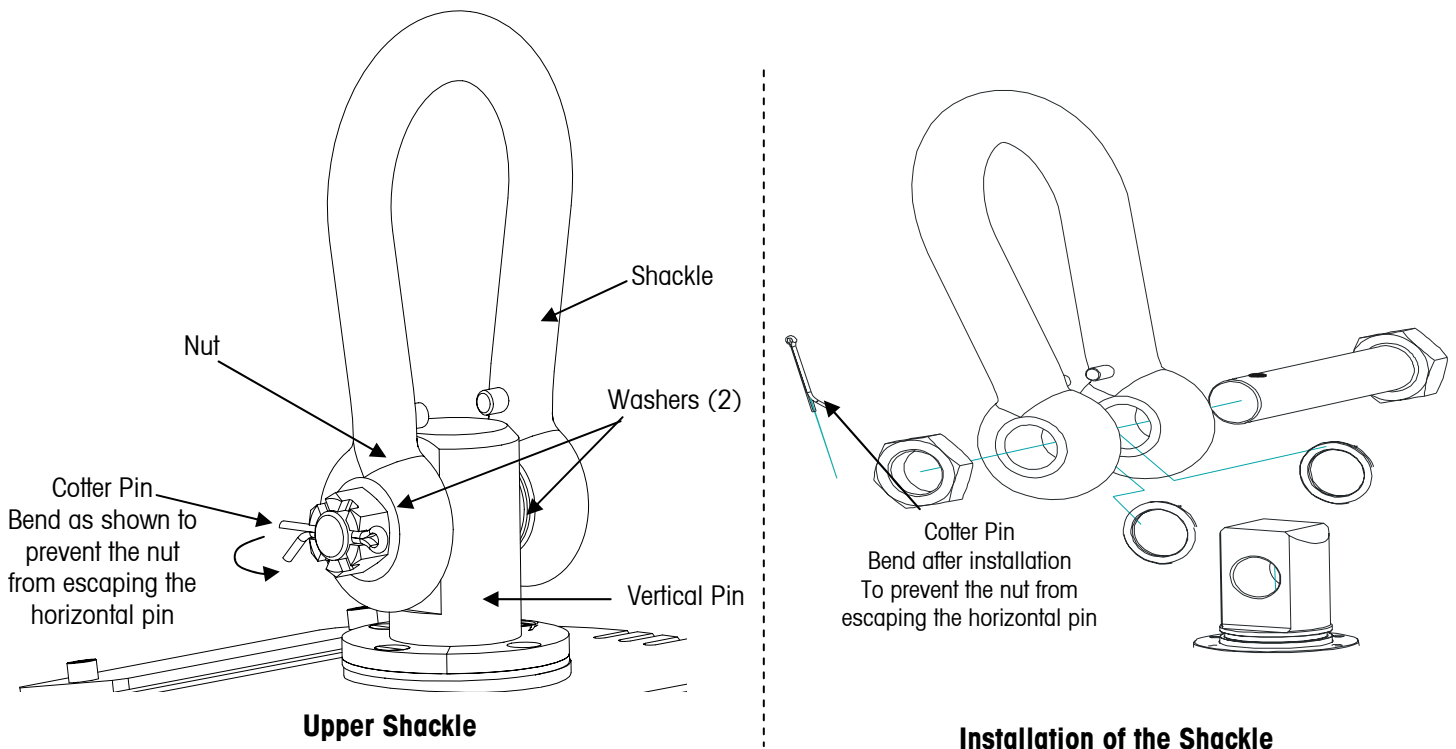

Front View – Crane Scale

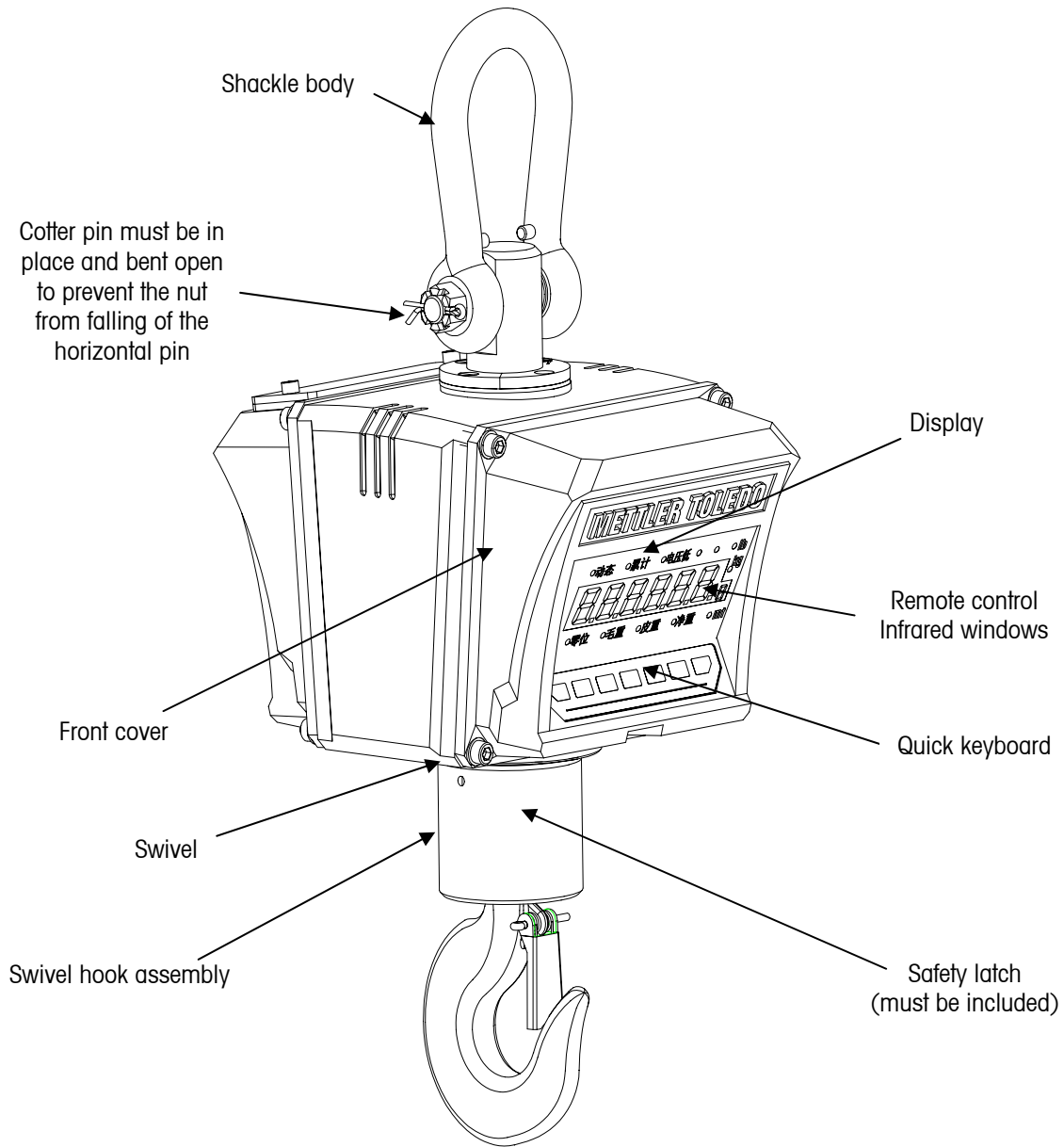

Rear View – Crane Scale

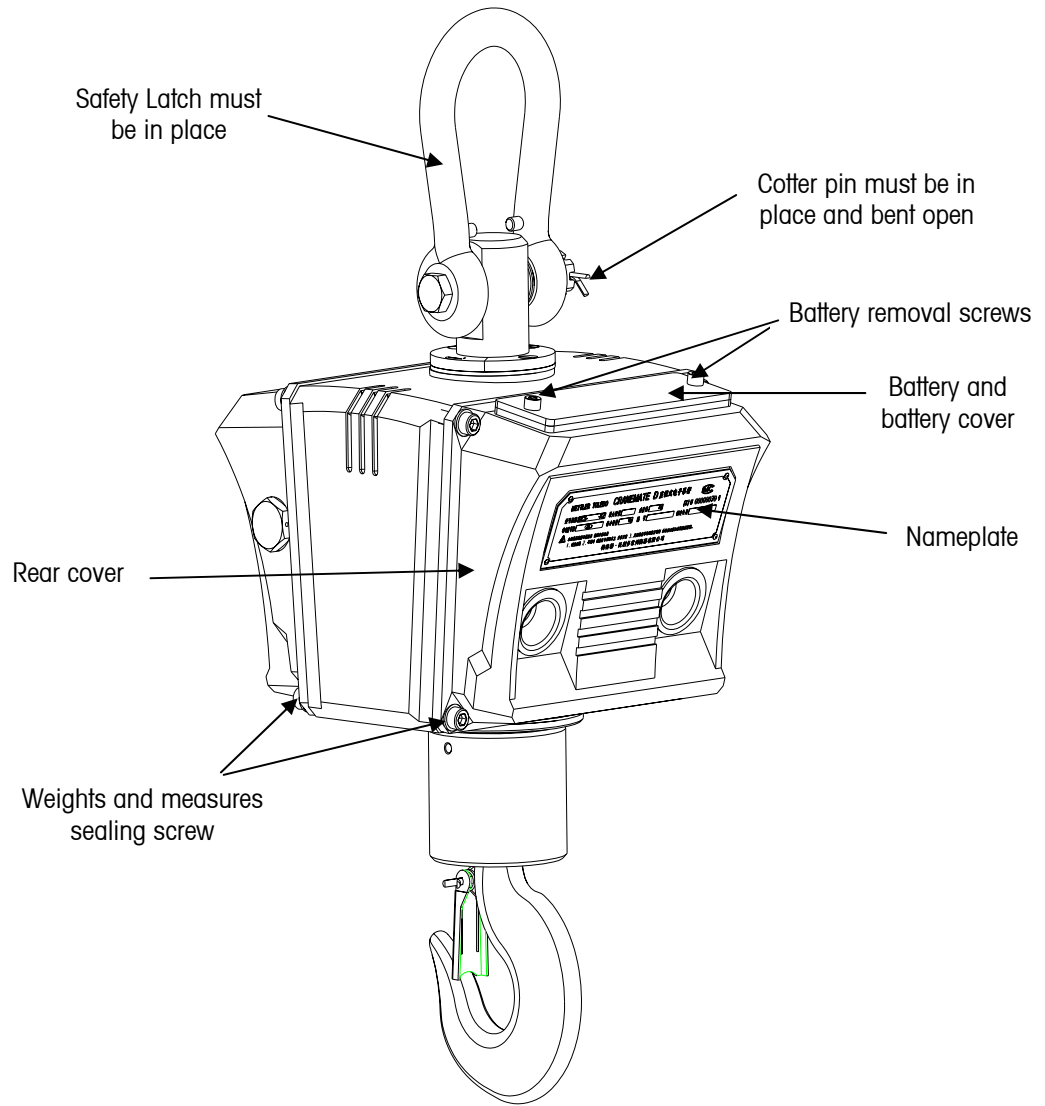

## ■ **POWER SUPPLY**

A sealed rechargeable lead-acid battery (6V7Ah) powers the scale and is fastened into the back of the scale by four screws in the rear cover. When you charge the battery for the first time, refer to the section on usage and maintenance for the battery for more details. You may want to replace the battery if the charging time reduces after considerable usage.

## ■ **HANGING THE SCALE**

Hang the scale from the bottom hook of a crane, and lock the secure latch to prevent the scale from falling from the hook. The secure latch is a safety feature of the hook on the crane. If your crane does not have a safety latch, or the safety latch is damaged, we recommend that you contact the crane manufacturer to obtain a hook with this safety feature.



## ■ **SIZING THE SCALE (IMPORTANT NOTE)**

The scale capacity should be equal or greater than the lifting capacity of the crane. For Example: If your crane has a lifting capacity of 1.5 tons we recommend that you chose a 2-ton scale. If you have selected a scale that has a gross capacity that is less than your crane lifting capacity, please contact your **Xpress** representative to obtain a larger unit. **Xpress** scales are available in various capacities up to 40 tons.

### **How to choose the correct crane scale size:**

**Lifting capacity of the crane \* Safety factor = Proper scale size.**

\*If your company has a safety program and regularly trains employees in safe crane operation and continually inspect safety related hardware for proper operation, use 1 for the safety factor.

If your employees are not trained in safe crane operation and could overload the crane, from time to time, use 2 or more as a safety factor.

## ■ VERIFYING THE SCALE

The scale has been calibrated in the factory. The end user can use it after installation and verification. In situations where the weight is used for trading purposes, a verification procedure must be performed by local or national officials, or by an approved organization. After passing the verification and granted the metrological certificate, the scale can be used for trade. For non-trade usage, the owner can use the scale after verification with known test weights.

## ■ CALIBRATING THE SCALE

Usually the end user shouldn't calibrate the scale after installation, except for using the scale for the first time and performing calibration cycle. An **Xpress** representative should normally perform this procedure. The user must have proper test weights and lifting equipment for calibration. Use test weights of at least 20% of scale capacity when calibrating the scale. Test weights of 80% or more of capacity are recommended. If you notice that the scale is not linear it is possible to perform a three-point calibration. See Appendix "Factory Default Settings".

## ■ TURNING THE SCALE ON/OFF

Press **On/Off**, the scale powers up, the display is illuminated all, then displays the component number and the software version number e.g. "Sr L.1", then performs a series of self tests. If everything is ok, the display returns to normal operating condition.

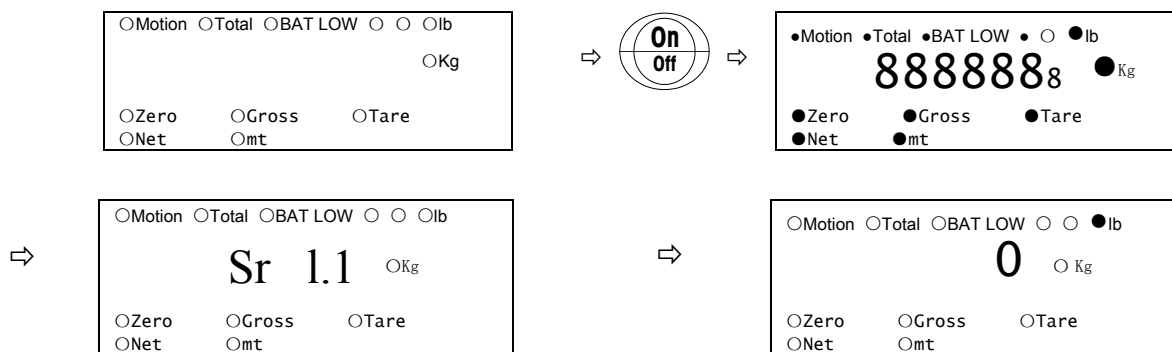

## ZERO FUNCTION

### Power-Up Auto Zero

The scale has power-up auto zero function. Zero range must be less than the preset value in the setting F1.6.3.

### Manual Push-Button Zero

In the Gross Mode, press **Zero**, if the gross value is within the zero range. The display will read zero and the zero cursor will light.

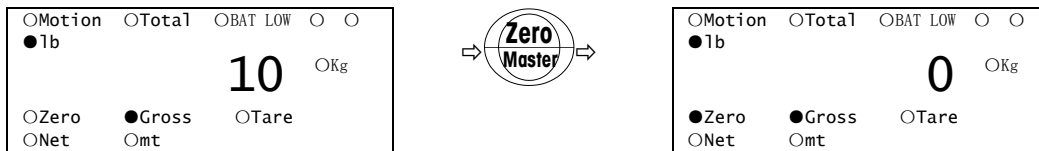

The scale will not accept a zero, or tare command, when the item being weighed is moving. The motion lamp lights to indicate that the item is in motion.

In the Gross Mode, if the zero cursor is not lit press 'Zero'. The zero cursor will light only when the load is  $0 \pm 1/4$  displayed increment.

## RECOMMENDATIONS FOR USE

- The end user should not calibrate the scale unless specifically trained on the calibration procedure for this product.
- When calibrating the scale linearly, perform multi-point linearization.
- Notices for charging the scale battery:



When the battery icon "L BAt" lights, the battery should be replaced.

Do not recharge the battery until it has been fully discharged, as this will shorten the life of the battery life.

## BATTERY NOTICE

- The (6V/5Ah rechargeable lead-acid battery) battery service life will be affected by the charge and discharge conditions. When used properly, it can be effectively charged/discharged 300 times before operating time is significantly reduced;
- The new battery can provide continuous operation once it is fully charged. The charge time is usually 15 hours if the battery is fully discharged. The charge time will be shorter if the battery is not fully discharged.
- Do not short the positive pole (+) and negative pole (-) when replacing the battery.
- Charge the battery at least every three months to keep it in good condition.
- The battery charge is shorter than normal if the battery is not used for a long period of time, e.g. more than two months. If this happens, please cycle the battery at least three times by charging it and using it until fully discharged. This returns the battery to the normal operating condition.
- The battery is not warranted due to the service time being greatly influenced by individual use.
- The battery charge and scale operating duration will decline with use as is typical with lead-acid batteries. We recommend replacement of the battery after 300 charging cycles. Replacement batteries are available from your local **Xpress** representative.
- If the keyboard isn't in use and the weight hasn't changed for five minutes, the scale will go into a power-saving mode and will display "SLEEP". The scale can be reactivated by pushing any key on the quick keyboard or by operating the remote control.

## YOUR XPRESS SCALE AT A GLANCE

### SAFETY NOTICE

Before operating XCL Crane Scale, the scale operator should carefully read and follow the operating precautions listed below:

- Follow all local and national safety laws.
- Follow all safety precautions from the crane manufacturer.
- Do **not** lift beyond rated load capacity of the crane, crane scale, sling chains, cables, or any item attached to the XCL Crane Scale.
- Do **not** operate the scale in areas designated for pedestrians – these are usually marked.
- Do **not** position the scale, or load, over personnel.
- Do **not** operate the crane scale if ropes, slings, cables, chains, etc. show any sign of defects or excessive wear.
- Before moving the load, make certain that load slings, load chains, or other lifting devices are fully seated in the saddle of the crane scale hook with hook latch closed.
- Do **not** drop the load when attached to the crane scale.
- Do **not** lift the load too rapidly.
- Do **not** collide the crane scale against any other object.
- Do **not** operate the crane scale if ropes, slings, cables, chains, etc. show any sign of defects or excessive wear.
- Before moving the load, make certain that load slings, load chains, or other lifting devices are fully seated in the saddle of the crane scale hook with hook latch closed.
- At no time should a load be lifted or suspended from the crane scale unless the operator is at the crane's master switch or pendulum with the crane power on.
- Keep the load as close to the floor as possible to minimize the possibility of an injury, should the load drop.
- When the crane scale is holding a load, the crane operator should remain at the master switch or pendulum.
- When a hitcher is used, it should be the joint responsibility of the crane operator and the hitcher to see that hitches are secure and that all loose material has been removed from the load before starting a lift.
- Do **not** lift loads with ropes, slings, cables, and chains that are not securely fastened around or to the load.
- All ropes, slings, cables, chains, etc. should be removed from the crane scale when not in use.
- Do **not** use slings, cables, chains, etc. which have not been approved for lifting.
- Replace any damaged or worn items.
- Do **not** service or adjust the scale when a load is attached.

## **HANDLING HOIST MOTION**

- After the crane scale hook has been positioned over the load, lower it until the load can be attached to the scale hook. As the scale hook approaches this level, reduce the speed so that the lowering can be stopped smoothly and quickly.
- If the slings are used to handle the load, the slings should be fully seated in the scale hook (saddle). With the scale hook latch closed, the scale hook should be started upward slowly until all slack has been taken out of the slings. Then ensure the load is properly balanced and the slings are properly positioned.
- Do **not** pull or push on a load once it is attached to the scale.
- Do **not** allow the load to swing when it is being moved
- Do **not** make abrupt starts and stops with the crane that could cause the loss of control of the load or excessively strain the lifting mechanisms (ropes, slings, cables, chains, etc.).

## **DISPLAY**

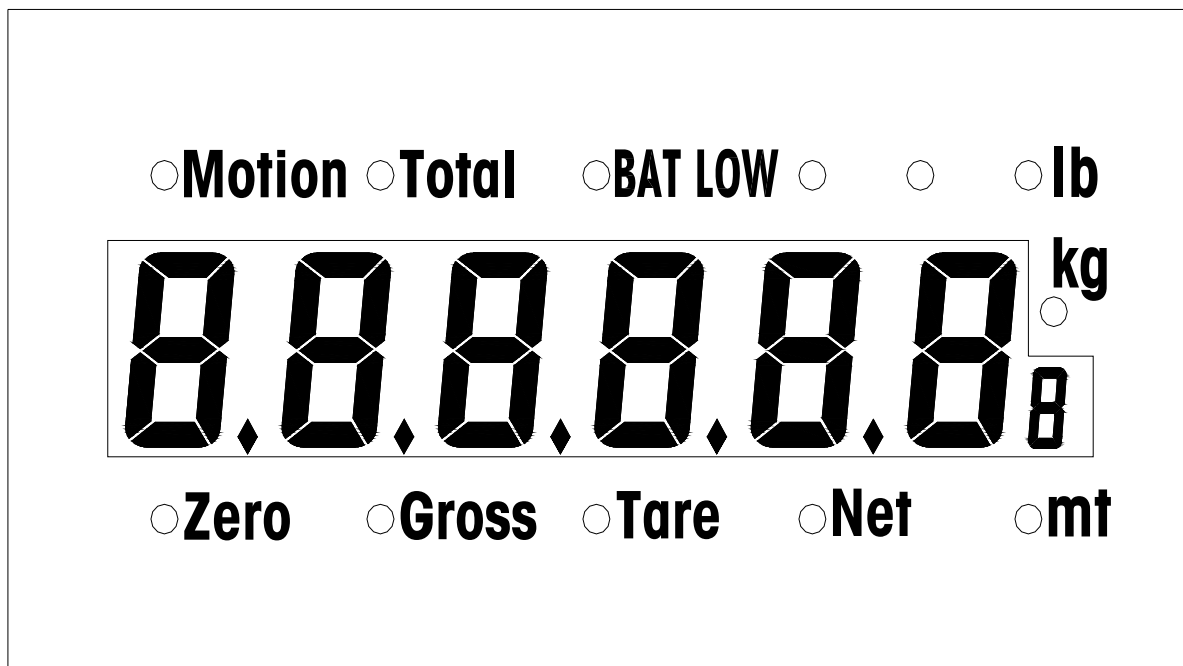

## **CURSORS**

Zero	This LED lights when the scale is within $\pm 1/4$ d of gross zero.
Gross	This LED lights when the display is displaying gross weight.
Tare	This LED lights when the display is displaying tare weight.
Net	This LED lights when the display is displaying net weight.
Total	This LED lights when the display shows accumulated weight or total count.
Motion	This LED lights when the scale is in motion.
BAT LOW	This LED lights when the battery voltage is lower than the preset value.
Kg	This LED lights when the current weight unit is <b>kg</b> (kilogram).
lb	This LED lights when the current weight unit is <b>lb</b> (pound).
mt	This LED lights when the current weight unit is <b>mt</b> (metric tonnes).
8	Indicates the current accumulator number.



## KEYBOARD

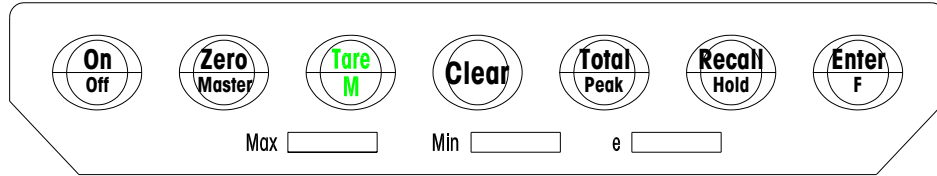

**Quick keyboard**

### Keyboard Function Description

Key	Function Description
On/Off	Turns the scale On and Off. Press and hold to turn Off.
Zero/Master	Press the key to set the zero reading of the scale. (in the Gross Mode)
Tare /M	Press the key in the Gross Mode to store the indicated weight as the Tare Weight. The instrument will display a net weight value of zero until additional weight is added. The unit will not tare when the scale is in motion.
Clear	When this key is pressed in the Net Mode, the crane scale display returns to the Gross weight display. Pressing this key in the Gross Mode will initiate a self-test.
Total/Peak	Pressing this key causes the current weight value to be added to the accumulator and the total LED indicator to flash for three seconds.
Recall	Press the key repeatedly, (on the instrument) displays the gross value, tare value, the accumulated value, and then returns to the Weight Mode. When inputting data, pressing the Recall button adds 1 to the reading.
Enter +Zero	Press Enter and release it. Then press Zero to enter into the Master Mode. At that point you can modify selected parameters. (See Setup F3.)
Enter + Tare	Press Enter and then release it. Then press Tare to sequentially recall all tare values, noting the tare number in the lower-right display. The main display will show the stored value.
Enter +Total	Press Enter and release it. Then press Total to enter the Peak Hold Mode.
Enter + Recall	When the weight is stable, press Enter and Recall and the current readings will be held. Press Clear key and the instrument quits the Weight Hold Mode and returns to the Normal Weighing Mode.

## REMOTE CONTROLLER

The remote controller can operate the scale the same as the quick keyboard does. In addition to the functions in the crane scale the remote control adds; 10 numerical key **0** to **9** plus **ID** and **Print** keys. Some operating modes, such as input of commodity ID's, numeric tare, and so on, are only accessed by the remote controller. These additional keys list as the following:

**Off** – Press **Off** key and the scale powers down.

**Note:** The scale **cannot** power up via the remote controller.

Use the On/Off key on the quick keyboard to return the scale to use.

**ID** – Used to input commodity ID number

**Print** – Does not function on this product

**0** to **9** – Entry of tare weight, ID number and entry of capacity, added load when calibrating.

The remote controller can be operated at distances up to 45 ft (15 m) from the scale. The scale's structure is fit for harsh industrial environments including corrosives, humidity, some shock loading, and dirt.

To test the controller, press any key while observing the indicator light on the upper left-hand side of the control itself.

If it fails to light every time a key is depressed, the batteries should be replaced. This unit requires two (2) AA cell Alkaline batteries. The batteries should be replaced every six months.

To replace the battery of the remote controller, take the remote controller from the yellow rubber housing. The procedure is as follows: Push the head of the remote controller slowly out of the rubber housing through the upper hole on the back of the housing, and pull the black controller out.

To avoiding changing the battery frequently, high-energy alkaline cells are recommended. After replacing the battery, slip the remote controller into the housing again.

If the remote control fails to function, clean the small window on the front of the scale and on the front of the controller with alcohol and a clean cloth.

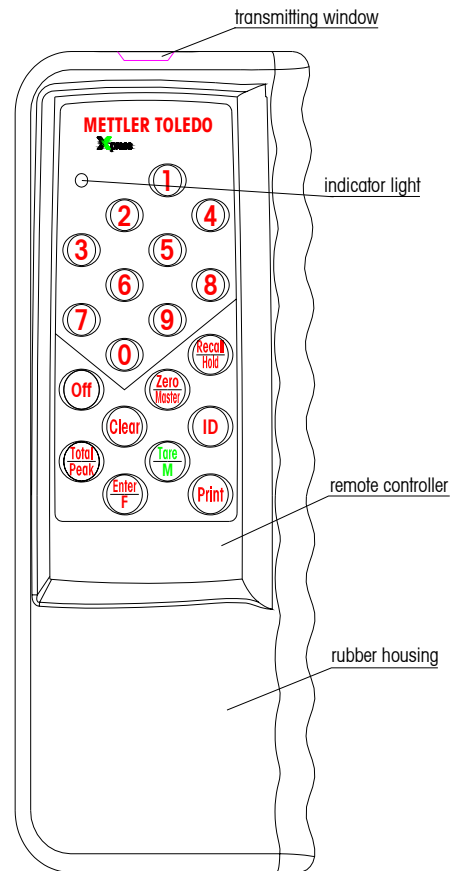

**Remote Controller**



### NOTICE

When operating the remote controller, please aim the transmitting window at the infrared receiving window in the bottom of the front housing!

## OPERATING YOUR SCALE

### PUSH-BUTTON TARE

In Gross Mode, pressing **Tare** causes the instrument to store the weight reading as the tare value. The net cursor lights and the scale displays zero.

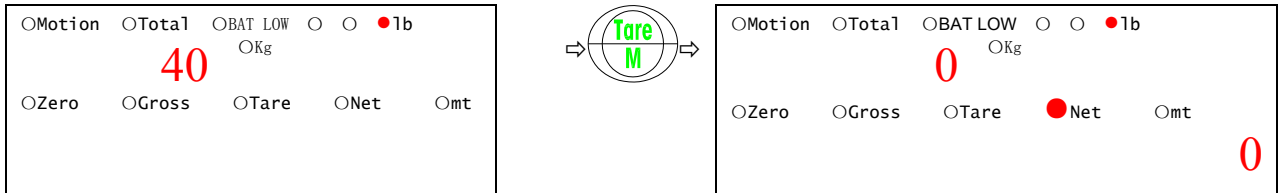

 Tare will not function when the scale is in motion.

### NUMERIC TARE

Press the numeric keys on the remote controller to input a manual tare value. Then press **Tare** key.

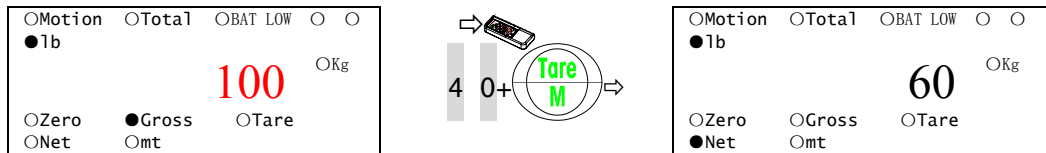

### CLEAR (REMOVAL OF TARE WEIGHT)

In Net Mode, press **Clear** and the instrument clears the tare weight, displays the gross weight, and the Gross cursor lights.

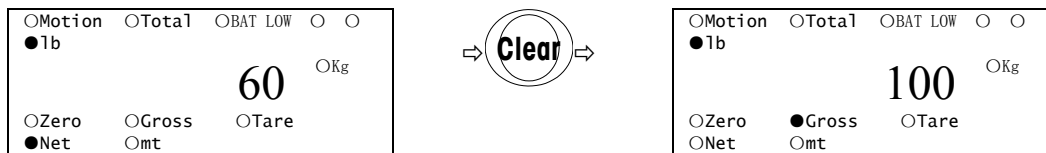

### WEIGHING (NORMAL GROSS WEIGHT)

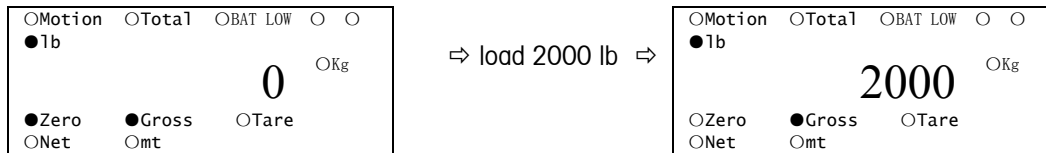

### ACCUMULATING

The accumulation function should be operated in Normal Weighing or Set Point Mode. See setup step. ([F2.5 X], X=0 or 2)

**MANUAL TOTAL**

In the Gross or Net Mode, pressing **Total** causes the weight readings to be added into the corresponding accumulator (Default value = 0), at the same time the total count adds 1.

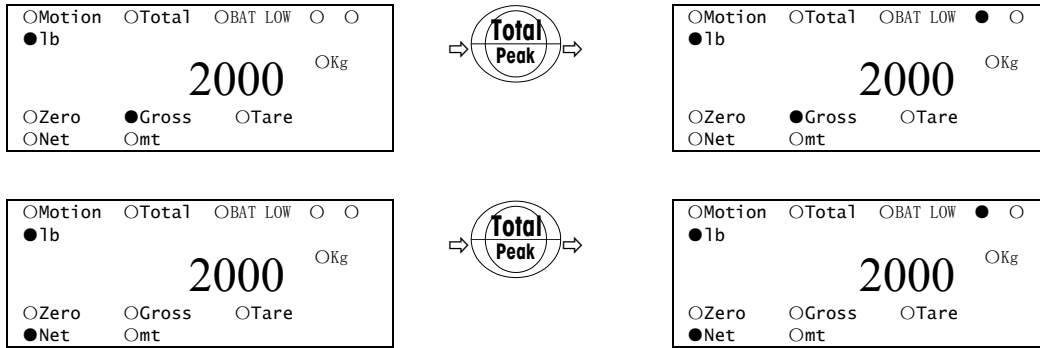

**AUTO TOTAL**

To complete this operation the scale must be in Auto Total Mode. (See the setting F2.4.2 x=2)

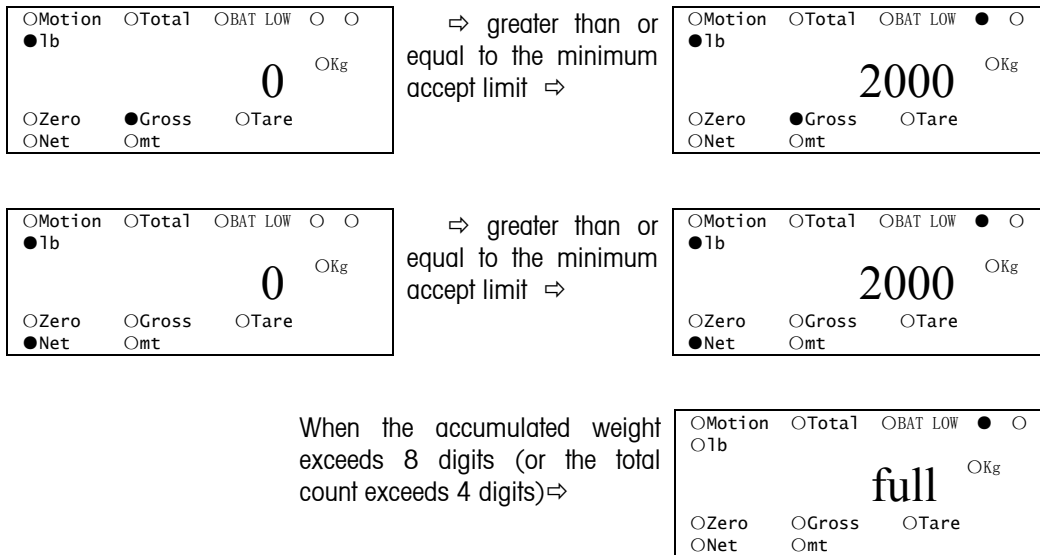

- After accumulating, the weight readings are added into the accumulator (Default value = 0), the total count automatically adds 1.
- When the readings are stable and greater than or equal to the minimum accept limit, the weight readings can be accumulated. (See the Setup F2.4.1)
- Only if the weight readings fall below 10 divisions, return to above the minimum accept limit and are stable, the next readings can be accumulated automatically!
- When the accumulated weight exceeds 8 digits (or the total count exceeds 4 digits), the instrument displays "FULL", at the same time the LED flashes for five seconds (illuminating for half a second, blanking for half a second), indicating that the accumulator overflows and that the last accumulation is invalid. Clear the accumulator this time.

**RECALL**

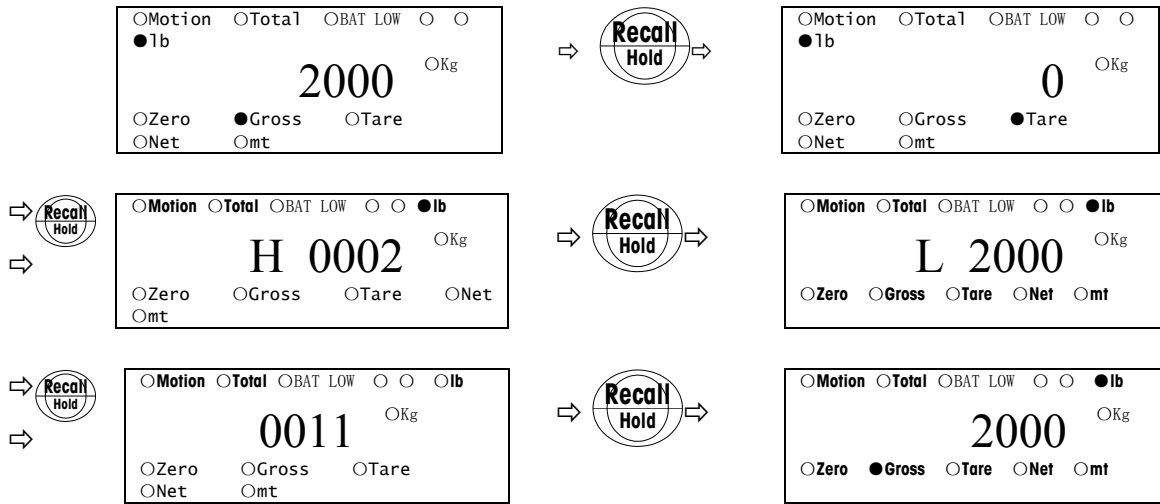

**CLEAR THE ACCUMULATOR**

When accumulation function is enabled ([F2.4.2 X] X=1 or X=2)

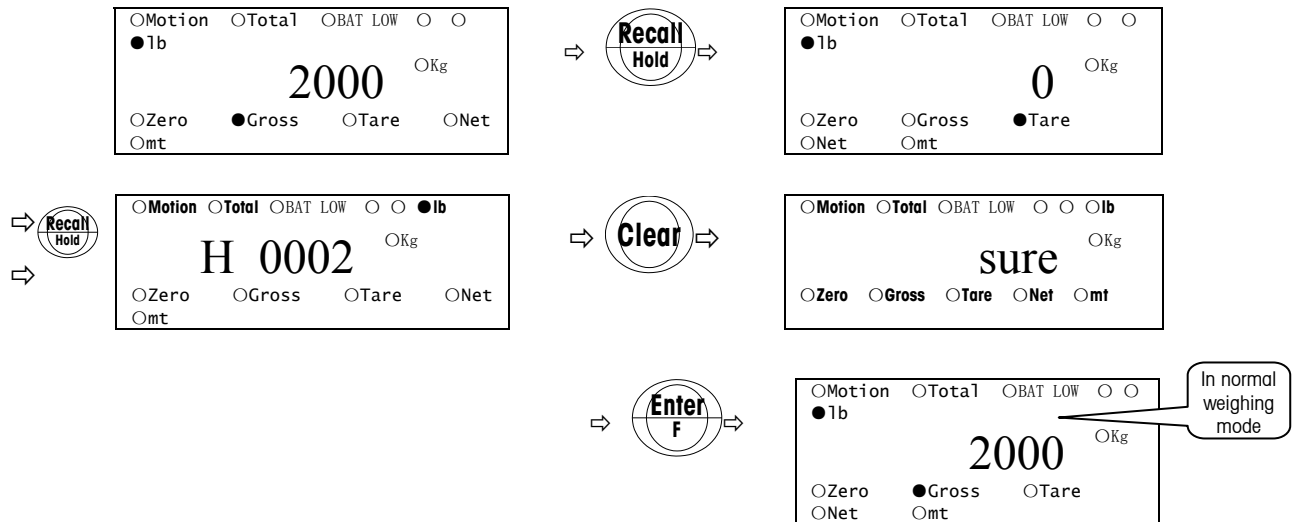

**PEAK WEIGHING OPERATION**

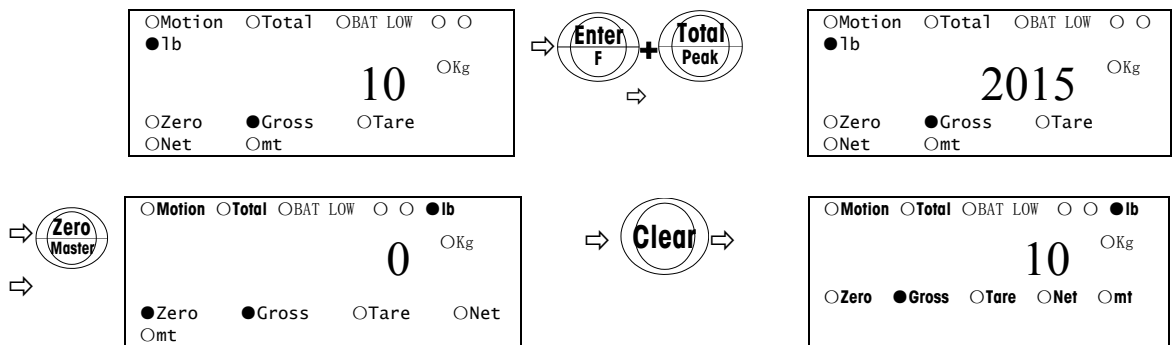

**LOAD HOLD**

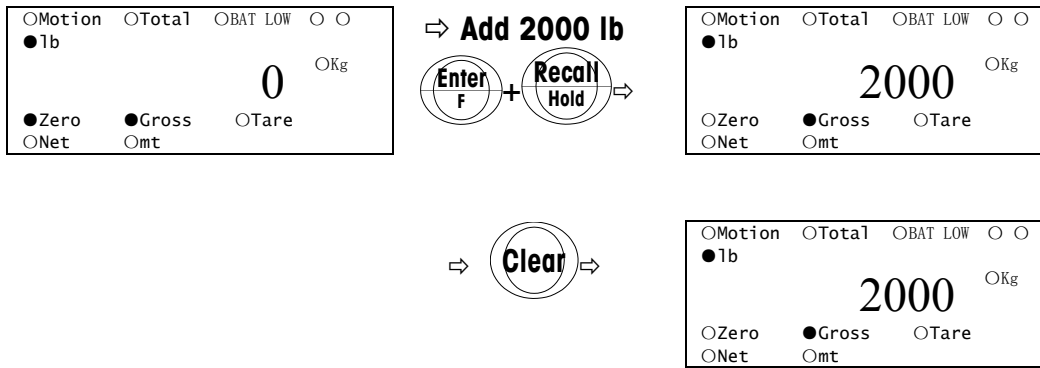

**SELF TEST**

In Gross Mode, press **Clear** and the instrument will enter into a self test. Display reads "00000", "11111", ..., "99999", "--p--", cursors and the remaining battery capacity messages [bAt X] (X=4, 3, 2, 1, 4-high 1-low). The instrument returns to the Normal Weighing Mode automatically.

**SLEEP MODE**

If the keyboard isn't in use and the weight hasn't changed for five minutes, the scale will go into a power-saving mode and will display "SLEEP". Pushing the quick keyboard or operating the remote controller can awaken the scale. To disable the SLEEP function, select the parameter "0" in the Setup F3.1.

**BRIGHTNESS ADJUSTMENT**

To adjust the brightness, select the parameter "0" or "1" in the Setup F3.2. See the "Factory Parameters Setup" and "Factory Default Settings" in the Appendix. The default parameter "0" indicates bright LED, the parameter "1" indicates bright LED and the LED brightness will darken automatically if the weight isn't obviously changed for five minutes, the parameter "2" indicates the LED brightness can be adjusted automatically according to ambient light levels.

**PRINTING**

**Printing the Ticket**

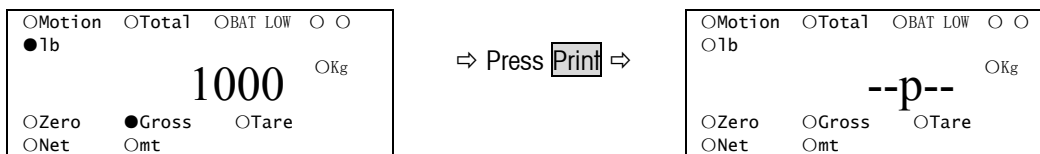

 Only the remote controller has this **Print** key.

**Printing the Accumulated Data**

In the Total Display Mode, press **Print** to output the accumulated weight. The numeral in the following set of parentheses represents the accumulator number. If the current accumulator number is zero, the parentheses can be omitted.

**TURNING THE SCALE OFF**

Press **On/Off** on the quick keyboard or **Off** on the remote controller, the scale powers down and the display goes blank.

## SCALE SOFTWARE SETUP

Several parameters in the scale can be changed to enable you to customize the scale to your individual needs. In the Master Mode, only parameters F3, F4, F5 and F6 can be changed. To change the parameters F1 and F2, please see "Servicing your Scale"

### SETUP PARAMETERS OVERVIEW

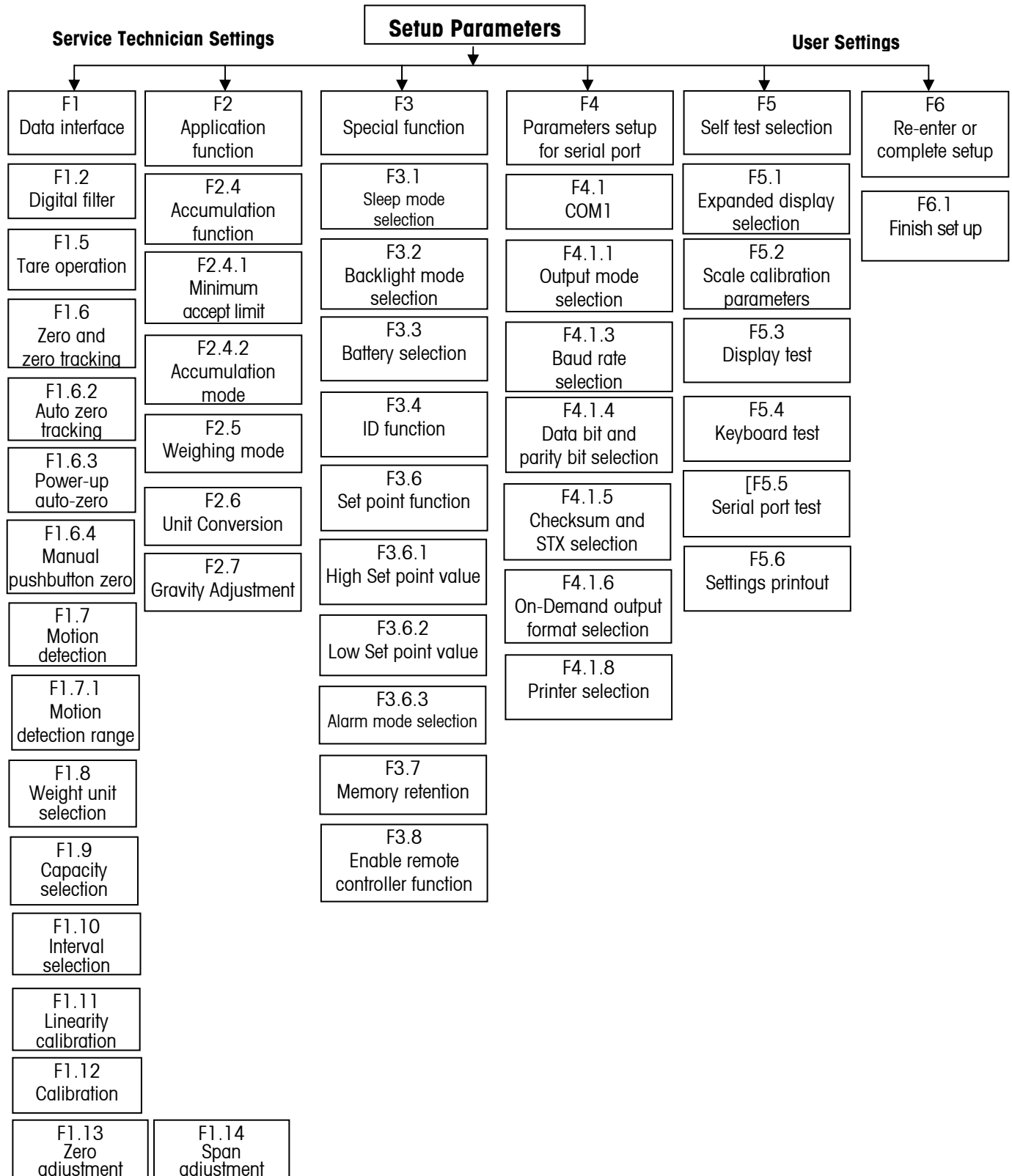

## ■ TO ENTER MASTER MODE

Press **Enter/F** and **Zero/Master** in turn and the instrument displays "F3.1" and enters into the Master Mode. Many of the parameters, such as F3, F4, F5, can be modified. To modify the parameters F1 and F2, the scale must be in Service Mode. (See Servicing Your Scale.)

During the setup, the function of each key lists as below:

**Tare** key—Used to select setup group or to setup parameters

**Zero** key—To step back through the setup procedure

**ENTER/F** key —To confirm the selected parameter

When inputting numerical data:

**Tare** key —The flashing digit shifts one position to the left indicating the digit that can be modified

**Recall** key—The flashing digit increments on each depression

## ■ SPECIAL FUNCTION GROUP

### [F3 ] Special Function

Press: **Tare**—Skips to step [F4 ]

**Enter**—Advances to step [F3.1 ]

**Zero**—Returns to step [F2 ]

### [F3.1 X] Sleep Mode Selection

Press: **Tare**—Displays next selectable parameter:

0—Disables sleep mode

1—Enables sleep mode (default)

If the keyboard isn't in use and the weight isn't obviously changed for five minutes, the instrument will go into a power-saving mode and will display "SLEEP". Pressing the quick keyboard or operation the remote controller will awaken it.

**Enter**— Accepts the selected parameter and advances to the next step [F3.2 X]

**Zero**—Returns to step [F3 ]

### [F3.2 0] Brightness Adjustment

Press: **Tare**—Displays next selectable parameters:

0—Brightness adjustment off (default)

1—Brightness adjustment on. The brightness will be off automatically after five minutes of nonuse.

2—Auto on/off (bright / dim according to ambient light levels)

**Enter**—Accepts the selected parameter and advances the step [F3.3 X]

**Zero**—Returns to step [F3.1 X]



**[F3.4 0] ID Function**

Press: **Enter**—Disables ID function. Advances to step [F3.6 ] in Set Point Mode or to step [F3.7 ],

**Tare**—Displays [F3.4 1]. Press **Enter** key to enable ID function, in Set Point Mode advances to step [F3.6 ], or to step [F3.7 X].

When disables ID function, each tare memory and accumulator has only one, default number is zero.

**Note:** The function is only for the Service Mode.

**[F3.6 ] Set Point Function (External output is only available via an option kit.)**

Press: **Tare**—Disables Set point function, skips to step [F3.7 X].

**Enter**—Enables Set point function, displays [F3.6.1 ].

**Note:** The function is only for the Service Mode.

**[F3.6.1 ] Inputting the High Set Point Value**

After one second the instrument displays:

[000000]—Use **Tare** and **Recall** key to input the high set point value, or key in the value directly from the remote controller. Then press **Enter** key to confirm advances to step [F3.6.2 ].

**[F3.6.2 ] Inputting the Low Set Point Value**

After one second the instrument displays:

[000000]—Use **Tare** and **Recall** key to input the low Set Point Value or key in the value directly from the remote controller. Then press **Enter** key to confirm and advance the step [F3.6.3 X].

**Note:** Only after Set Point Mode is selected in step [F2.5 X] (set X=2), this function can be available. The high Set Point Value must be greater than the lower value.

**[F3.6.3 1] Display Alarm Mode Selection**

Press: **Tare**—Displays next selectable parameters:

0—The weight reading doesn't flash when the weight "reaches" the Set Point Value.

1—The weight reading flashes on and off when the weight "reaches" the Set Point Value.

**Enter**—Accepts the selected parameter and advances to the next step [F3.7 X]

**Zero**—Returns to step [F3.6 ]

The word "reaches" means that the weight reading is greater than or equal to the high Set Point Value or less than or equal to the low Set Point Value.

**[F3.7 0] Memory Retention**

Press: **Enter**—Disable memory retention and advances to the next step [F3.8 X]

**Tare**— Displays [F3.7 1]. Press **Enter** key to enable memory retention and advance to the next step [F3.8 X].

When Memory retention is enabled, the instrument returns to the last status (Zero, Gross/Net status, etc.) when powering up.

**Zero**—Returns to step [F3.7 ]

**[F3.8 1] Enable Remote Controller Function**

Press: **Enter**—Enables remote controller. The cursor “Remt” lights in normal operation and advances to the next step [F4 ].

**Tare**—Displays [F3.8 0]. Press **Enter** key to confirm and to disable the remote controller. This advances on to the next step [F4 ].

**Zero**—Returns to step [F3.7 X]

**Zero**—Returns to step [F3 ]

**Zero**—Returns to step [F4 ]

**[F4 ] setup parameters for serial port**

Press: **Tare**-----Not enter the entry of the setup for serial port, advances to step [F5 ]

**Enter** -----Enters the entry of the setup for serial port, advances to step [F4.1 ].

**Zero**-----Returns to step [F3 ]

**[F4.1 ] com1**

Press: **Tare**-----Not enter the entry of the setup for COM1, advances to step [F5 ]

**Enter** -----Enters the entry of the setup for COM1, advances to step [F4.1.1 X]

**Zero**-----Returns to step [F4 ]

**[F4.1.1 X] output mode selection**

Press: **Tare**-----Displays next parameter, selectable parameters:

0-----On-Demand mode (default)

1-----Continuous data mode

**Enter** -----Accepts the selected parameter, advances to step [F4.1.3 ]

**Zero**-----Returns to step [F4.1 ]

**[F4.1.3 ] baud rate selection, displays the current baud rate [001200] after a second (default)**

Press: **Tare**-----Displays next baud rate, selectable baud rates: 300, 1200, 2400, 4800, and 9600

**Enter**-----Accepts the selected parameter, advances to step [F4.1.4 X]

**Zero**-----Returns to step [F4.1.1 X]

**[F4.1.4 X] data bit and parity bit selection**

Press: **Tare**-----Displays next parameter, selectable parameters:  
0-----7 data bits, parity bit is zero  
1-----7 data bits, odd parity  
2-----7 data bits, even parity (default)  
3-----8 data bits, no parity bit (uses for transmitting characters)  
**Enter**-----Accepts the selected parameter, advances to step [F4.1.5 X]  
**Zero**-----Returns to step [F4.1.3 ]

**[F4.1.5 0] Checksum and STX selection**

Press: **Tare**-----Displays next parameter, selectable parameters:  
0-----Disables Checksum (default)  
1-----Enables Checksum. Checksum is defined as the 2's complement of the seven low order bits of the binary sum of all characters preceding the checksum character, including the <STX> and <CR> characters.  
**Enter**-----Accepts the selected parameter, advances to step [F4.1.6 X]  
**Zero**-----Returns to step [F4.1.4 X]

**[F4.1.6 X] On-Demand output format selection**

Press: **Tare**-----Displays next parameter, selectable parameters:  
0-----No data output  
1-----Single-line: displayed weight (default)  
2-----Single-line: Gross, Tare, Net  
3-----Multi-line: Gross, Tare, Net  
**Enter**-----Accepts the selected parameter, advances to step [F4.1.8 X]  
**Zero**-----Returns to step [F4.1.5 X]

**[F4.1.8 X] printers selection**

Press: **Tare**-----Displays next parameter, selectable parameters:  
1-----Selects micro-printers (default). No print format No.2 (micro-printers must have Chinese font library if needed.)  
2-----Selects PQ30 printers  
**Enter**-----Accepts the selected parameter, advances to step [F5 X]  
**Zero**-----Returns to step [F4.1.6 X]  
Self test group

## [F5 ] Self-Test Selection

Press: **Tare**—Advances to step [F6 ]

**Enter**—Enters the entry of self-test setup and displays [F5.1 X].

**Zero**—Returns to step [F4 ]

## [F5.1 X] Expanded Display Selection

Press: **Tare**—Displays next selectable parameters:

0—Disables the expanded display (default)

1—Enables the expanded display. In Weighing Mode, the instrument displays internal scale interval.

(**Note:** One display scale interval is equal to ten internal scale intervals.)

**Enter**—Accepts the selected parameter, advances to step [F5.2 0]

**Zero**—Returns to step [F5 ]

## [F5.2 0] Display Scale Calibration Parameters

Press: **Enter**—Skips to step [F5.3 0]

**Tare**— Displays [F5.2 1], press **Enter** key, displays [FinE0], after two seconds displays [XXXXXX], records or modifies the empty scale reading, then press **Enter** key, displays [SPAn1], after two seconds displays [XXXXXX], records or modifies the span coefficient, then press **Enter** key, displays [LinE1], after two seconds displays [XXXXXX], records or modifies the linearity coefficient No. 1, press **Enter** key, displays [LinE2], after two seconds displays [XXXXXX], records or modifies the linearity coefficient No.2, press **Enter** key, advances to next step.

**Zero**—Returns to step [F5.1 X]

## [F5.3 0] Display Test

Press: **Enter**—Advances to step [F5.4 0]

**Tare**—Displays [F5.3 1]. Press the **Enter** key and the instrument enters the display test and displays all possible numbers from all zeros through all nines. Then all the cursors illuminate and it performs an internal check on the memory. Advances to step [F5.4 0].

**Zero**—Returns to step [F5.2 0]

**Note:** If the instrument finds any errors during the memory check it will display a corresponding error code.

## [F5.4 0] Keyboard Test

Press: **Enter**—Advances to step [F5.5 0]

**Tare**—Displays [F5.4 1]. Press **Enter** key, the instrument enters the keyboard test, operators press a key, and the instrument displays a corresponding key code, press **Enter** key to end this test, advances to next step.

**Zero**—Returns to step [F5.3 0]

**[F5.5 0] Serial Port Test (Not used on this product.)**

Press: **Enter**—Advances to step [F5.6 0]

**Tare**—Displays [F5.5 1]. Short-circuit TXD and RXD pin of the output connector, and press **Enter** key, the instrument enters the serial port test. The weight display reads the transmitting numeral on the two leftmost digits, and the receiving numeral on the two rightmost digits, the two numerals should be same. The display reading begins from "01", then "02", "03" ... "09", "00", "01", goes round and round. Press **Enter** key to end this test, advances to next step.

**Zero**—Returns to step [F5.4 0]

**[F5.6 0] Settings Printout (Not used on this product.)**

Press: **Enter**—Advances to step [F6 ]

**Tare**—Displays [F5.6 1]. Press **Enter** key, the instrument outputs the settings.

**Zero**—Returns to step [F5.5 0]

**[F6 ] Re-Enter or Complete Setup**

Press: **Tare**—Advances to step [F1 ] start over

**Enter**—Goes to [F6.1 X] finish setup

**Zero**—Returns to step [F5 ] previous selection

**[F6.1 X] Finish Setup**

Press: **Tare**—Displays next selectable parameters:

1—Saves your selection

2—Restores the previous parameters

3—Restores the factory default, displays "SvrE?" (Save).

**Enter**—Accepts the selected parameter

**Zero**—Returns to step [F6 ]

If item 1 or 2 is selected, the scale quits the setup program and returns to Normal Weighing Mode; If item 3 is selected it displays "SvrE?" (Save).

Press **Enter** key, the instrument restores the factory default parameters, quits the setup program, and returns to Normal Weighing Mode.

Press **Tare** key, returns to step [F6 ]

**■ QUIT THE SETUP PROGRAM**

To quit the setup program and return to Normal Weighing Mode, follow the procedure as below:

Pressing the **Clear** key, displays [F6 ]; Pressing the **Enter** key displays [F6.1 1]; To save the setup parameters press the **Enter** key; The scale quits the setup program and returns to Normal Weighing Mode.

**CLEANING AND MAINTAINING YOUR SCALE**

	 <b>WARNING</b>
	<p><b>DISCONNECT ALL POWER TO THIS UNIT BEFORE INSTALLING, SERVICING, CLEANING, OR REMOVING THE FUSE. FAILURE TO DO SO COULD RESULT IN BODILY HARM AND/OR PROPERTY DAMAGE.</b></p>

**REGULAR MAINTENANCE AND INSPECTION**

**Connection**

Check the connecting pieces, the split pins and setscrews for looseness or deformity. Replace any missing pieces or tighten loose screws/pins at once.

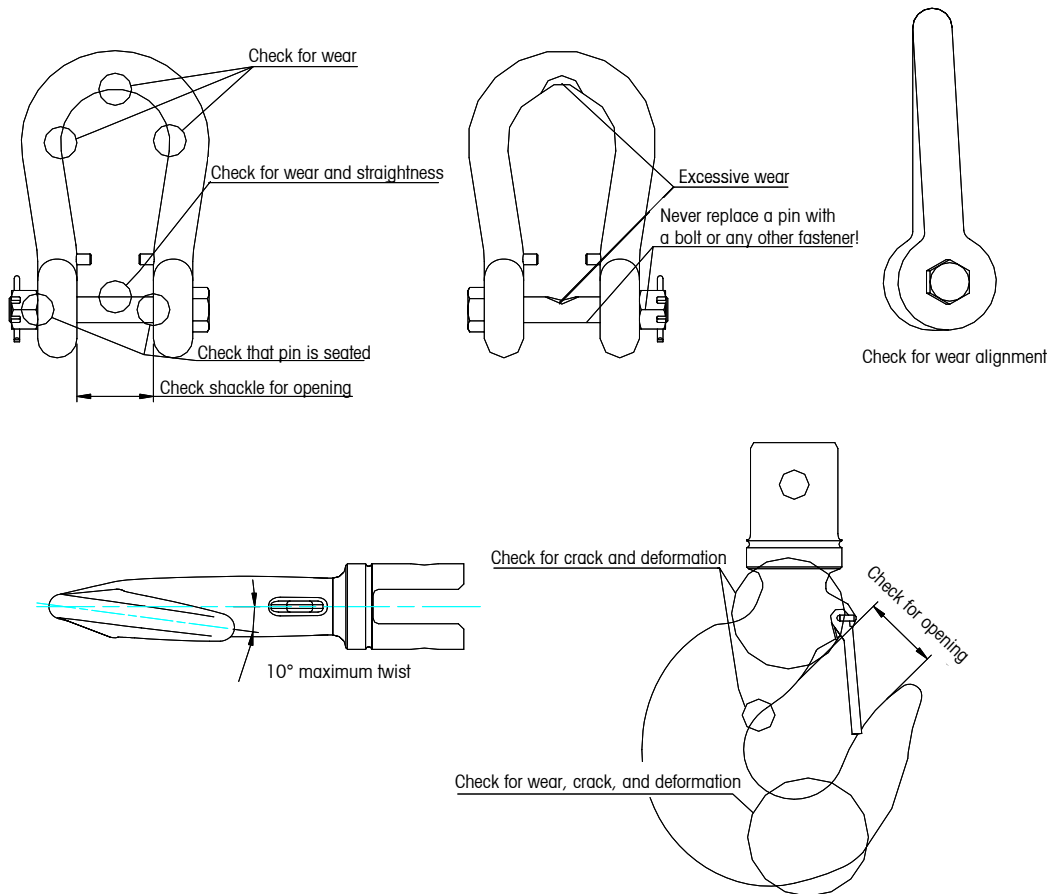

**Surface damage**

Check the shackle and hook surfaces for mechanical damage such as cracks, etc. and discard the damaged ones and replace them!

### Deformation

- Check the opening (See the upper figure) of the hook. When the value is 10% greater than the initial dimension, the hook must be discarded!
- Check the twist deformation of the hook. When the twist angle of the hook body is greater than 10°, the hook must be discarded!
- The shackle and hook should not have any plastic deformation or they must be discarded!

### Abrasion and Corrosion

- Check the shackle and hook for abrasion and corrosion. The actual dimensions in use on the dangerous section should not less than 95% of their initial dimension or they must be discarded!
- DO NOT permit to repair the shackle and hook system by welding!
- Replace the secure latch periodically, i.e., whenever it is damaged or broken. This will prevent the scale from falling should it encounter a no load or zero load.

### **CLEANING**

Clean the keyboard with a soft cloth that has been dampened with a mild window cleaner or detergent. DO NOT use any type industrial solvent or chemicals.

Regular inspections with written service records periodically by a qualified service technician are also recommended.

### **POWER SUPPLY AND CHARGING**

A sealed, rechargeable lead-acid battery (6V7Ah) powers the XCL Crane Scale. The operator should check the remaining battery capacity often. Change the battery when the low battery indicator “●” lights. When the scale displays [L Bat], indicating that the battery capacity is too low for the scale to work, the battery must be charged immediately or the scale will power down automatically.

### Charging

Remove the bolt on the top of the rear cover and pull out the battery. Plug the charger shipped with the scale into a power outlet. Then plug another small end of the charger’s power cord into the charging port of the battery and charge the scale. The charger indicator is red to start and when the indicator turns yellow, charging is complete.



### **WARNING**

- Charge the battery when it has been not in use for a period of more than three months.
- Charging time: 24 hours
- Daily charging time: 8-10 hours, 20°C above; 12-16 hours, 20°C below.
- Keep the battery away from any heat source and avoid exposure to the sun.
- When not in use for a long time, remove the battery.

### Remote Controller Power Supply

Two ordinary alkaline cells (“AA” size, 1.5V) are used. If the indicator light does not flash when operating the remote controller, the battery must be immediately replaced.

## **TROUBLESHOOTING**

The instrument is designed for durable, reliable, and virtually error free operation. If problems do occur after powering on, do not attempt to repair the scale or instrument before you have determined the source of the problem. Begin by performing the diagnostic tests described in the previous section. If the problem persists, you can use the error codes table below to help identify the problem.





## SERVICING YOUR SCALE



For the following services, please contact your **Xpress** representative at [www.mt.com/xpress](http://www.mt.com/xpress).

	<b>WARNING</b>
	<b>DISCONNECT ALL POWER TO THIS UNIT BEFORE INSTALLING, SERVICING, CLEANING, OR REMOVING THE FUSE. FAILURE TO DO SO COULD RESULT IN BODILY HARM AND/OR PROPERTY DAMAGE.</b>

<b>CAUTION</b>
<b>BEFORE CONNECTING OR DISCONNECTING ANY INTERNAL ELECTRONIC COMPONENTS OR INTERCONNECTING WIRING BETWEEN ELECTRONIC EQUIPMENT, ALWAYS REMOVE POWER AND WAIT AT LEAST THIRTY (30) SECONDS BEFORE ANY CONNECTIONS OR DISCONNECTIONS ARE MADE. FAILURE TO OBSERVE THESE PRECAUTIONS COULD RESULT IN DAMAGE TO OR DESTRUCTION OF THE EQUIPMENT, OR BODILY HARM.</b>

### ■ TO ENTER SERVICE MODE

Remove the hexagonal seal screw on the right side of the front cover and press the push-button in the hole. The instrument displays "F1" and enters the Service Mode. All parameters including the calibration parameters can be modified.

**Note:** Entering Service Mode voids weights and measures approval and the unit must be reprovved.

During the setup, the function of each key lists as below:

**Tare** key—Used to select setup group or setup parameters,

**Zero** key—To step back through the setup procedure,

**ENTER/F** key —To confirm the selected parameter,

When inputting numerical data:

**Tare** key —The flashing digit shifts one digit leftwards, this digit can be modified.

**Recall** key—The flashing digit increments on each depression.

**Note:** in the following description, the "F" in "[FX.X]" displays on the far left side of the display.

### ■ CALIBRATION GROUP

#### [F1 ] Weighing Functions

Press: **Tare**—Skips to step [F2 ]

**Enter**—Enters the calibration group, displays [F1.2 X]

#### [F1.2 X] Digital Filter

Press: **Tare**—Displays next digital filter parameter, selectable parameters:

0—Filter disabled

1—Light filter

2—Medium filter (default)

3—Heavy filter

**Enter**—Accepts the selected parameter, enters step [F1.5 X]

**Zero**—Returns to step [F1 ]

**[F1.5 X] Tare Operation**

Press: **Tare**—Displays next selectable parameters:

0—Disables tare operation

1—Enables tare operation, tare range: 0~100% F.S.(default)

**Enter**—Accepts the selected parameter, enters step [F1.6 ]

**Zero**—Returns to step [F1.2 ]

**[F1.6 ] Zero and Zero Tracking**

Press: **Tare**—Skips to step [F1.7 ]

**Enter**—Enters next step, displays [F1.6.2 X]

**[F1.6.2 X] Auto Zero Tracking**

Press: **Tare**—Displays next selectable parameters:

0—Disables auto zero tracking (default)

1—Zero tracking threshold value:  $\pm 0.5d$

2—Zero tracking threshold value:  $\pm 1.0d$

3—Zero tracking threshold value:  $\pm 3d$

**Enter**—Accepts the selected parameter, advances to step [F1.6.3 X]

**Zero**—Returns to step [F1.6 ]

**[F1.6.3 X] Power-up Auto Zero**

Press: **Tare**—Displays next selectable parameters:

0—Disables power-up auto zero

1—Power-up auto-zero range:  $\pm 2\%$

2—Power-up auto-zero range:  $\pm 10\%$  (default)

3—Power-up auto zero range:  $\pm 100\%$

**Enter**—Accepts the selected parameter, advances to step [F1.6.4 X]

**Zero**—Returns to step [F1.6.2 X]

**[F1.6.4 X] Manual Push-button Zero**

Press: **Tare**—Displays next selectable parameters:

0—Disables manual pushbutton zero

1—Manual zero range:  $\pm 2\%$  (default)

2—Manual zero range:  $\pm 20\%$

3—Manual zero range:  $\pm 100\%$

**Enter**—Accepts the selected parameter, advances to step [F1.7 ]

**Zero**—Returns to step [F1.6.3 X]

**[F1.7 ] Motion Detection**

Press: **Tare**—Skips motion detection setup and advances to step [F1.8 ]

**Enter**—Enters motion detection setup, advances to step [F1.7.1 X]

**[F1.7.1 X] Motion Detection Range**

Press: **Tare**—Displays next selectable parameters:

0—Disables motion detection

1—Motion detection range:  $\pm 0.5d$  (default)

2—Motion detection range:  $\pm d$

3—Motion detection range:  $\pm 3d$

**Enter**—Accepts the selected parameter, advances to step [F1.8 X]

**Zero**—Returns to step [F1.7 ]

**[F1.8 X] Weight Unit Selection**

Press: **Tare**—Displays next selectable parameters:

0—Displays weight unit: kg

1—Displays weight unit: lb

2—Displays weight unit: t

3—Displays weight unit: mt (metric tonne)

**Enter**—Accepts the selected parameter, advances to step [F1.9 ]

**Zero**—Returns to step [F1.7 ]

**[F1.9] Capacity Selection**

After two seconds displays the current capacity.

Press: **Tare**—Enters the entry of capacity and displays "000000". The far left digit flashes use **Tare** and **Recall** keys to input the capacity value, or key in the capacity value directly via the numerical key.

**Enter**—Confirms and advances to step [F1.10 ]

**Zero**—Cancels the selection, Returns to step [F1.8 ]

[F1.10] Interval Selection

After two seconds it displays the current interval "XXXXXX".

Press: —Displays next interval

—Confirms the selected interval, advances to step [F1.11 X]

Capacity and interval selection must meet the values in the next table. The others are shown but are only available on heavier capacity units.

Interval Capacity	0.02	0.05	0.1	0.2	0.5	1	2	5	10	20	50
100	√	√	√								
250		√	√	√							
500			√	√	√						
1000				√	√	√					
2000					√	√	√				
2500					√	√					
5000						√	√	√			
10000							√	√	√		
15000							√	√	√		
20000								√	√	√	
25000								√	√	√	
30000								√	√	√	
40000									√	√	
50000									√	√	√
60000									√	√	√
80000										√	√
<del>100000</del>	<b>Do not use</b>									√	√

Capacity and Interval

[F1.11 X] Linearity Calibration

Press : —Display next selectable parameters:

0—Disables linearity calibration (default)

1—Enables linearity calibration

—Accepts the selected parameter, advances to step [F1.12 0]

—Returns to step [F1.9 ]

[F1.12 0] Calibration (Do NOT use this step unless you have sufficient test weights - See below.)

Press: —Skips to step [F1.13 0]

—Displays [F1.12 1], press  again, the instrument enters the calibration procedure.

## ■ **DISPLAYS**

### Standard Calibration (F1.11=0)

[E SCL]—Remove all weight from the scale, press **Enter** key once the scale has settled and is stable, the instrument displays [15 SCL], counts down from 15 to 0 while recording zero, then displays [Add Ld].

**Note:** When displaying [E SCL], press **Zero** to return to step [F1.12 0].

[Add Ld]—Pick up test weights of at least 20% of scale capacity. A test weight of 80% or more of capacity is recommended for highest accuracy. Then press **Enter**, the instrument displays [000000], the leftmost digit flashes, use **Tare** and **Recall** keys to input the test weights value, or key in the value directly from the remote controller, then press the **Enter** key to confirm your selection, the instrument displays [15 S[L] , counts down from 15 to 0 while recording span, then displays [[AL d], indicating that the calibration is completed, and displays [F1.13 0] after 2 seconds.

**Note:** When displaying [Add Ld], press **Zero** to return to step [E SCL].

For best results, the test weight must relate to the lowest significant digit. A test weight not corresponding to the lowest significant digit will be automatically rounded to the closest digit. If the scale has a scale capacity yielding a lowest significant digit of 5 kg then adding 4 kg would cause an error.

### Three-Point Linear Calibration (F1.11=1)

[E SCL]—Remove all weight from the scale, press **Enter** once the scale is stable, the instrument displays

[5 SCL], counts down from 15 to 0 while recording zero, then displays [Add HI].

[Add HI]—Pick up test weights of at least 50 to 100% of scale capacity. Test weights of 80% or more of capacity are recommended for highest accuracy. Then press **Enter**, the instrument displays [000000], the leftmost digit flashes, use **Tare** and **Recall** key to input the test weights value, or key in the value directly from the remote controller, then press **Enter** key to confirm, the instrument displays [15 SCL] , counts down from 15 to 0 while recording high span, then displays [Add L0]

**Note:** When displaying [Add HI], press **Zero** to return to step [E SCL].

For best results the test weight must relate to the lowest significant digit. A test weight not corresponding to the lowest significant digit will be automatically rounded to the closest digit. If the scale has a scale capacity yielding a lowest significant digit of 5 kg then adding 4 kg would cause an error.

[Add L0]—Pick up test weights of at least 10 to 50% of scale capacity, then press **Enter**, the instrument displays [000000], the leftmost digit flashes, use **Tare** and **Recall** key to input the test weights value, or key in the value directly from the remote controller, then press **Enter** key to confirm, the instrument displays [15 S[L] , counts down from 15 to 0 while recording low span, then displays [[AL d], indicating that the calibration is completed, and displays [F1.13 0] after 2 seconds.

**Note:** When displaying [Add L0], press **Zero** to return to step [Add HI].

For best results the test weight must relate to the lowest significant digit. A test weight not corresponding to the lowest significant digit will be automatically rounded to the closest digit. If the scale has a scale capacity yielding a lowest significant digit of 5 kg then adding 4 kg would cause an error.

### [F1.13 0] Zero Adjustment

Press: **Enter**—Skips to step [F1.14 0]

**Tare**—Displays [F1.13 1], advances to zero adjustment. Remove all weight from the scale, press **Enter** key, the instrument displays [15 S[L] and counts down from 15 to 0 while recording zero, then displays [F1.14 0].

**Zero**—Returns to step [F1.12 0]

### [F1.14 0] Span adjustment

Press: **Enter**—Skips to step [F2 0]

**Tare**—Displays [F1.14 1], advances to span adjustment.

Press **Enter** key, the instrument displays [000000], use **Tare** and **Recall** key to input the test weights value, or key in the value directly from the remote controller, press **Enter** to confirm, the instrument displays [15 S[L] and counts down from 15 to 0 while recording span, then advances to next step.

**Zero**—Returns to step [F1.13 0]

**Note:** Pick up test weights on the scale in weighing mode, then enters the Setup, advances to step [F1.14 0], repeat the span adjustment operation following the above step.

**Warning:** The test weight value must be divided exactly by significant figure of the selected scale interval. For example, significant figure of scale interval 0.02 is 2.

## ■ APPLICATION GROUP

### [F2 ] Application Function

Press: **Tare**—Skips to step [F3 ]

**Enter**—Enters application group, displays [F2.4 ]

### [F2.4 ] Accumulation Function

Press: **Tare**—Disables accumulation function, advances to step [F2.5 ]

**Enter**—Advances to step [F2.4.1 ]

**Zero**—Returns to step [F2 ]

### [F2.4.1 1] Minimum Accept Limit to be Accumulated, After One Second Displays [XXXXXX]

Press: **Zero**—Enters the entry of minimum acceptable weight which will be accumulated the unit displays [000000], the leftmost digit flashes. Use **Tare** and **Recall** key to input the minimum accept limit, or key in the value directly from the remote controller. Then

Press: **Enter** key to confirm, advances to step [F2.4.2 X],

Press: **Zero** key to cancel the input, Returns to step [F2.4 ].

The unit will not accept the next accumulated value unless the weight value has changed by ten digits since the last accumulation.

**[F2.4.2 X] Accumulation Mode**

Press: **Tare**—Displays next selectable parameters:

0—Disables accumulation (default)

1—Manual accumulation

2—Auto accumulation (only if the weight readings fall below 10 divisions, then return to or above the minimum accept limit and are stable, the next readings can be accumulated.)

**Enter**—Accepts the selected parameter, enters step [F2.5 X]

**Zero**—Returns to step [F2.4.1 ]

**[F2.5 X] Weighing Mode**

Press: **Tare**—Displays next selectable parameters:

0—Normal Weighing Mode (default)

1—Peak hold mode, the instrument displays the detected Maximum weight and holds it, simultaneously the cursor "PEAK" lights. In this mode the accumulation, function is not available.

2—Set point mode (not available without an installed option).

**Enter**—Accepts the selected parameter, advances to step [F3 ]

**Zero**—Returns to step [F2.4 ]

**[F2.6 X] Unit Conversion**

Press: **Tare**—Displays next selectable parameters:

0—no conversion

1—kg

2—lb

If the current display unit is kg, select the parameter "2" to convert kilograms into pounds.

If the current display unit is lb, select the parameter "1" to convert pounds into kilograms.

**Enter**—Accepts the selected parameter, advances to step [F2.7 ]

**Zero**—Returns to step [F2.5 ]

**[F2.7 12] Gravity GEO Adjustment**

Press: **Tare**—Displays next selectable parameters: 0~31

The scale is calibrated with a Geo code of 12 at the factory. To adjust the factory calibration to your specific area, refer to Appendix E (page 41) for your Geo code. Enter the new Geo code and calibration will automatically be adjusted for your desired location.

**Enter**—Accepts the selected parameter, advances to step [F3 ]

**Zero**—Returns to step [F2.6 ]

## BATTERY REPLACEMENT

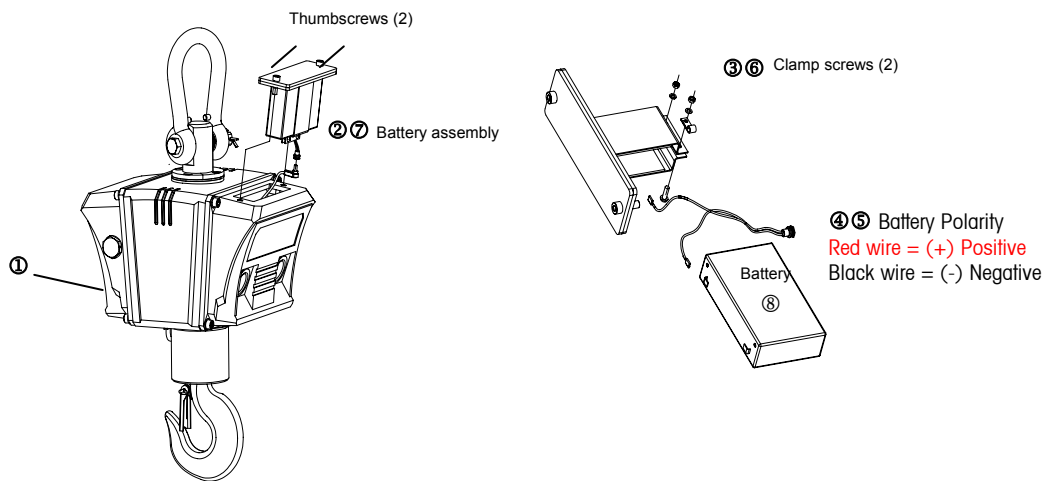
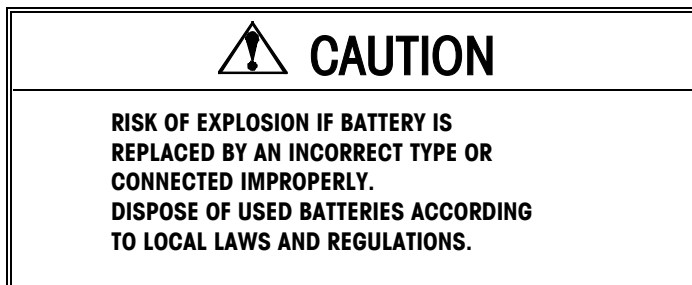

1. Turn the scale off by pressing the on/off pushbutton on the keyboard
2. Slowly remove the battery assembly all from the top of the scale – it is held by two thumbscrews
3. Loosen the two screws that clamp the battery into the battery assembly
4. Remove the two plastic battery connectors from the pins on the battery
5. Replace and reconnect the battery – please note that the **red wire is (+)** and the black wire is (-) polarity



6. Replace the battery and tighten the two screws
7. Replace the battery assembly.
8. Dispose of the "used" (old) battery in according to local laws and regulations.



## APPENDIX

### DEFAULT SETUP PARAMETERS

<b>F1</b>	<b>Scale Interface</b>	<b>Default</b>	<b>F3</b>	<b>Special Function Group</b>	<b>Default</b>
F1.2	Digital filter	2	F3.1	Sleep mode	1
F1.5	Tare operation	1	F3.2	Backlight mode	0
F1.6.2	Auto zero tracing	0	F3.3	Battery selection	0
F1.6.3	Power up zero range	2	F3.4	ID function	0
F1.6.4	Pushbutton zero range	1	F3.6.3	Display alarm mode selection	0
F1.7.1	Motion range	1	F3.7	Memory retention	0
F1.8	Unit selection	0	F3.8	Remote controller function	1
F1.9	Scale capacity	NA	<b>F4</b>	<b>Serial port Setup</b>	<b>Default</b>
F1.10	Interval	NA	F4.1.1	Output mode selection	0
F1.11	Linearity calibration	0	F4.1.3	Baud rate selection	1200
F1.12	Calibration	0	F4.1.4	Data bit and parity bit selection	2
F1.13	Zero adjustment	0	F4.1.5	Checksum selection	0
F1.14	Span adjustment	0	F4.1.6	On-Demand output format selection	1
<b>F2</b>	<b>Environment</b>	<b>Default</b>	F4.1.8	Printers selection	1
F2.4.1	Minimum accept limit	0	<b>F5</b>	<b>Diagnosis</b>	<b>default</b>
F2.4.2	Accumulation mode	0	F5.1	Expanded display	0
F2.5	Weighing mode	0	F5.2	Scale calibration parameters	0
F2.6	Unit conversion	2	F5.3	Display test	0
F2.7	Gravity adjustment	12	F5.4	Keyboard test	0
			F5.5	Serial port test	0
			F5.6	Settings printout	0

## ERROR MESSAGES

Error Code	Description	Remedy
E1	EPROM checkout error	1.Power off and back on 2.Replace PCB
E2	Internal RAM checkout error	1.Power off and back on 2.Replace PCB
E3	EEPROM checkout error	1.Power off and back up 2.Replace EEPROM
E35	Calibration test weight is too light.	Add additional test weight
E37	The scale is in motion	Re-calibration
Full	Data memory overflow	Clear transaction record
---	Under load indication, under load is below power-on auto zero limit.	1.Press <b>Zero</b> and empty the scale 2.Check for loose load cell cable connections
---	Overload indication, overload is 9 divisions greater than full capacity.	Decrease the load check that the scale has not been damaged
● BAT LOW	Low battery voltage	Charge the battery
L bAt	Low battery voltage, power off automatically in a minute.	Charge the battery immediately
SLEEP	Automatically enters the SLEEP mode when the weight isn't obviously changed and the scale isn't in use for 5 minutes.	Press any key on the quick keyboard or the remote controller to activate the scale.

**■ SPECIFICATIONS**

**Capacity:** 100 kg/250 lb, 250 kg/500 lb, 500 kg/1000 lb, 1 ton/2500 lb, 2.5 ton/5000 lb, 5 ton/10,000 lb

**Accuracy Class:** (III) NTEP 5000 (Optional certificate)

**Indication Stabilizing Time:** < 10s

**Safe Overload:** 200% Full Scale (F.S.)

**Ultimate Overload:** 100 kg – 5 ton:  $\geq 500\%$  F.S.

**Fatigue Life:** 1 million times

**Tare Range:** 0 to 100% F.S.

**Zero Range:**  $\pm 2\%$  F.S. or 20% F.S.

**Operating Temperature:**  $-20^{\circ}\text{C}$  to  $+50^{\circ}\text{C}$

**Relative Humidity:** 10% to 95%, non-condensation

**Storage Temperature:**  $-30^{\circ}\text{C}$  to  $+60^{\circ}\text{C}$

**Enclosure Protection Class:** IP65

**Main Specifications of Load Cell**

**Model:** TSA

**Input Resistance:**  $2200 \pm 50 \Omega$

**Output Resistance:**  $2000 \pm 50 \Omega$

**Load Cell Sensitivity:**  $1.5 \pm 0.1 \text{ mv/v}$  (100 kg, 250 kg, 500 kg, 1 ton)  
 $2 \pm 0.3 \text{ mv/v}$  (2.5 ton, 5 ton)

**Compensated Temperature Range:**  $-10^{\circ}\text{C}$  to  $+40^{\circ}\text{C}$

**Excitation Voltage:**  $5 \pm 0.5\text{V}$  (DC)

**Safe Overload:** 200% F.S

**Ultimate Overload:** 500% F.S

**Protection Class:** IP67

**GEO VALUE TABLE**

Use the following geo codes if you relocate the XCL to a site other than the original location where it was calibrated.

Northern and Southern latitude in degrees and minutes	Height above sea-level in meters										
	0	325	650	975	1300	1625	1950	2275	2600	2925	3250
	325	650	975	1300	1625	1950	2275	2600	2925	3250	3575
	Height above sea-level in feet										
0	1060	2130	3200	4260	5330	6400	7460	8530	9600	10660	11730
1060	2130	3200	4260	5330	6400	7460	8530	9600	10660	11730	
0° 0' — 5° 46'	5	4	4	3	3	2	2	1	1	0	0
5° 46' — 9° 52'	5	5	4	4	3	3	2	2	2	1	0
9° 52' — 12° 44'	6	5	5	4	4	3	3	2	2	1	1
12° 44' — 15° 6'	6	6	5	5	4	4	3	3	2	2	1
15° 6' — 17° 10'	7	6	6	5	5	4	4	3	3	2	2
17° 10' — 19° 2'	7	7	6	6	5	5	4	4	3	3	2
19° 2' — 20° 45'	8	7	7	6	6	5	5	4	4	3	3
20° 45' — 22° 22'	8	8	7	7	6	6	5	5	4	4	3
22° 22' — 23° 54'	9	8	8	7	7	6	6	5	5	4	4
23° 54' — 25° 21'	9	9	8	8	7	7	6	6	5	5	4
25° 21' — 26° 45'	10	9	9	8	8	7	7	6	6	5	5
26° 45' — 28° 6'	10	10	9	9	8	8	7	7	6	6	5
28° 6' — 29° 25'	11	10	10	9	9	8	8	7	7	6	6
29° 25' — 30° 41'	11	11	10	10	9	9	8	8	7	7	6
30° 41' — 31° 56'	12	11	11	10	10	9	9	8	8	7	7
31° 56' — 33° 9'	12	12	11	11	10	10	9	9	8	8	7
33° 9' — 34° 21'	13	12	12	11	11	10	10	9	9	8	8
34° 21' — 35° 31'	13	13	12	12	11	11	10	10	9	9	8
35° 31' — 36° 41'	14	13	13	12	12	11	11	10	10	9	9
36° 41' — 37° 50'	14	14	13	13	12	12	11	11	10	10	9
37° 50' — 38° 58'	15	14	14	13	13	12	12	11	11	10	10
38° 58' — 40° 5'	15	15	14	14	13	13	12	12	11	11	10
40° 5' — 41° 12'	16	15	15	14	14	13	13	12	12	11	11
41° 12' — 42° 19'	16	16	15	15	14	14	13	13	12	12	11
42° 19' — 43° 26'	17	16	16	15	15	14	14	13	13	12	12
43° 26' — 44° 32'	17	17	16	16	15	15	14	14	13	13	12
44° 32' — 45° 38'	18	17	17	16	16	15	15	14	14	13	13
45° 38' — 46° 45'	18	18	17	17	16	16	15	15	14	14	13
46° 45' — 47° 51'	19	18	18	17	17	16	16	15	15	14	14
47° 51' — 48° 58'	19	19	18	18	17	17	16	16	15	15	14
48° 58' — 50° 6'	20	19	19	18	18	17	17	16	16	15	15
50° 6' — 51° 13'	20	20	19	19	18	18	17	17	16	16	15
51° 13' — 52° 22'	21	20	20	19	19	18	18	17	17	16	16
52° 22' — 53° 31'	21	21	20	20	19	19	18	18	17	17	16
53° 31' — 54° 41'	22	21	21	20	20	19	19	18	18	17	17
54° 41' — 55° 52'	22	22	21	21	20	20	19	19	18	18	17
55° 52' — 57° 4'	23	22	22	21	21	20	20	19	19	18	18
57° 4' — 58° 17'	23	23	22	22	21	21	20	20	19	19	18
58° 17' — 59° 32'	24	23	23	22	22	21	21	20	20	19	19
59° 32' — 60° 49'	24	24	23	23	22	22	21	21	20	20	19
60° 49' — 62° 9'	25	24	24	23	23	22	22	21	21	20	20
62° 9' — 63° 30'	25	25	24	24	23	23	22	22	21	21	20
63° 30' — 64° 55'	26	25	25	24	24	23	23	22	22	21	21
64° 55' — 66° 24'	26	26	25	25	24	24	23	23	22	22	21
66° 24' — 67° 57'	27	26	26	25	25	24	24	23	23	22	22
67° 57' — 69° 35'	27	27	26	26	25	25	24	24	23	23	22
69° 35' — 71° 21'	28	27	27	26	26	25	25	24	24	23	23
71° 21' — 73° 16'	28	28	27	27	26	26	25	25	24	24	23
73° 16' — 75° 24'	29	28	28	27	27	26	26	25	25	24	24
75° 24' — 77° 52'	29	29	28	28	27	27	26	26	25	25	24
77° 52' — 80° 56'	30	29	29	28	28	27	27	26	26	25	25
80° 56' — 85° 45'	30	30	29	29	28	28	27	27	26	26	25
85° 45' — 90° 00'	31	30	30	29	29	28	28	27	27	26	26

**PHYSICAL DIMENSIONS**

Model	Capacity [lb]	Resolution [lb]	Dimensions ["]							Shipping Information			
			H	C	D	φ1	F	φ2	φ3	L ["]	W ["]	H ["]	WT [lb]
XC01L-00	250	0.1	22.8	15	1.6	2	4.1	2.4	0.8	31.5	19.7	15.7	77.0
XC02L-00	500	0.2								31.5	19.7	15.7	77.0
XC03L-00	1000	0.5								31.5	19.7	15.7	77.0
XC04L-00	2500	1								31.5	19.7	15.7	77.0
XC05L-00	5000	2	29.5	15	1.8	2.4	5.5	3.5	1.1	31.5	19.7	15.7	77.0
XC06L-00	10,000	5								31.5	19.7	15.7	77.0

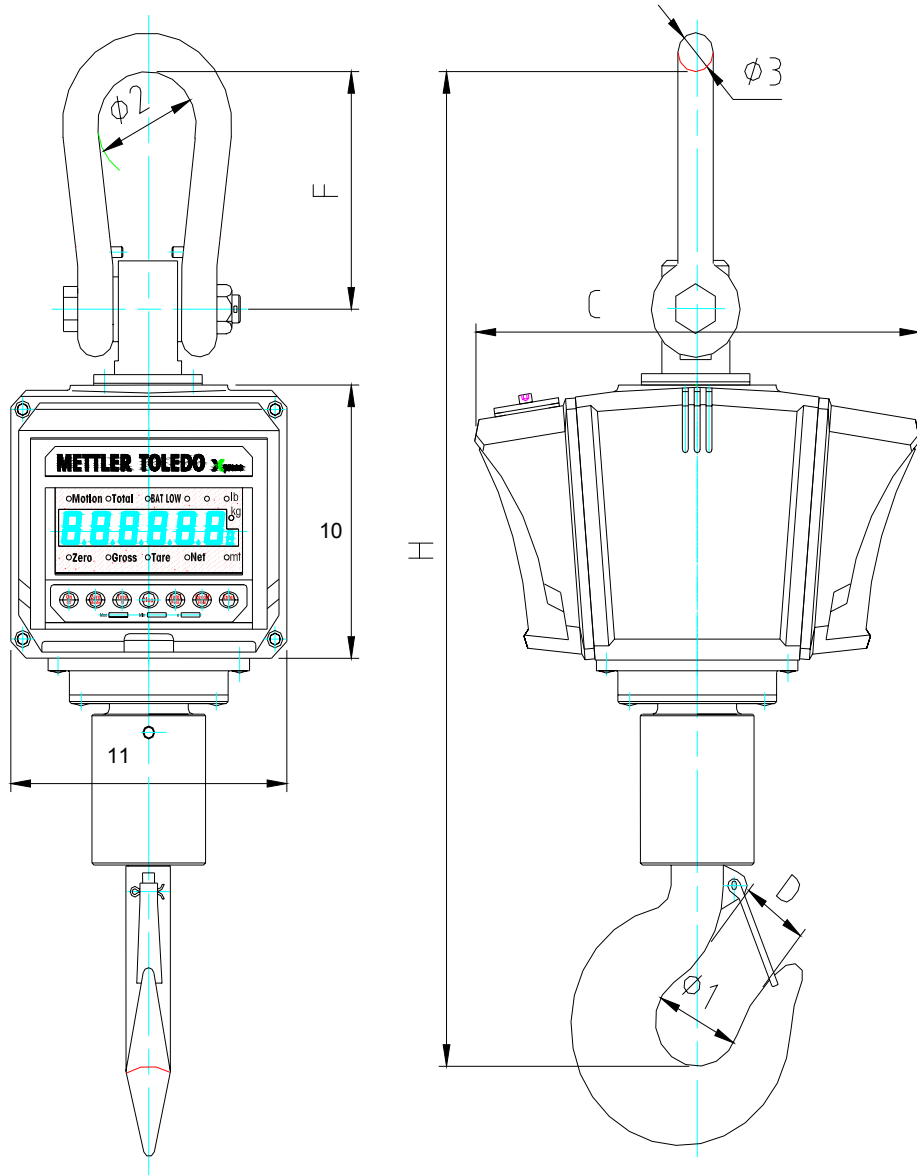

Notes

**Xpress**

Mettler-Toledo, Inc.  
60 Collegeview  
Westerville, OH 43081

5/2004  
MTX04-OM032.1E